



# TESTE MULTIMANDRINO AD INTERASSE REGISTRABILE MULTIPLE HEADS WITH ADJUSTABLE CENTRE DISTANCE

FORATURA  
DRILLING



MASCHIATURA  
TAPPING



## SPECIFICHE TECNICHE TECHNICAL FEATURES

Modello *Type* 821 Codice *Code* 111843.100

Mandrino porta-utensile per pinza <i>Tool-holder for collet</i>	<b>ER 20</b>
Rapporto di trasmissione <i>Transmission ratio</i>	1:1
Velocità max <i>Max speed</i>	3000 rpm
Potenza max mandrino <i>Spindle max power</i>	1.5 Kw
Carico assiale max <i>Max axial load</i>	1500 N
Peso <i>Weight</i>	2.5 Kg
Lubrificazione a grasso <i>Grease lubricated</i>	

## OPZIONI OPTIONS

Pinza ER20 DIN 6499/B <i>ER20 collet DIN 6499/B</i>	411220.100
Flangia di collegamento <i>Quill clamp</i>	410130.000
Trascinatore <i>Driver</i>	
Giunto <i>Joint</i>	
Chiave <i>Clamping wrench</i>	410220.000

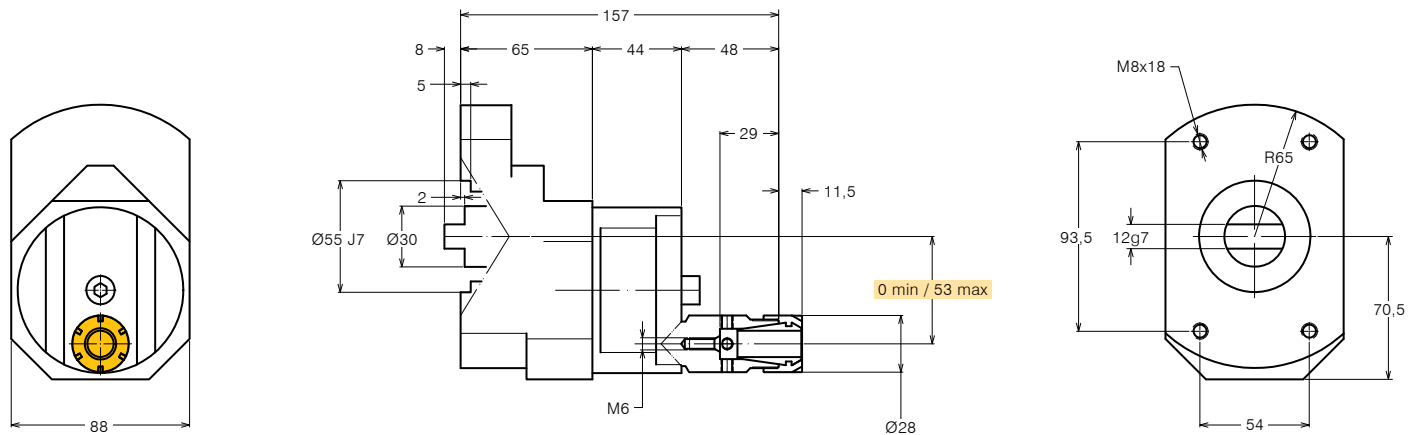

## SPECIFICHE TECNICHE TECHNICAL FEATURES

Modello *Type* 822 Codice *Code* 111844.100

Mandrino porta-utensile per pinza <i>Tool-holder for collet</i>	<b>ER 20</b>
Rapporto di trasmissione <i>Transmission ratio</i>	1:1
Velocità max <i>Max speed</i>	3000 rpm
Potenza max mandrino <i>Spindle max power</i>	1.5 Kw
Carico assiale max <i>Max axial load</i>	1500 N
Peso <i>Weight</i>	3.6 Kg
Lubrificazione a grasso <i>Grease lubricated</i>	

## OPZIONI OPTIONS

Pinza ER20 DIN 6499/B <i>ER20 collet DIN 6499/B</i>	411220.100
Flangia di collegamento <i>Quill clamp</i>	410130.000
Trascinatore <i>Driver</i>	
Giunto <i>Joint</i>	
Chiave <i>Clamping wrench</i>	410220.000

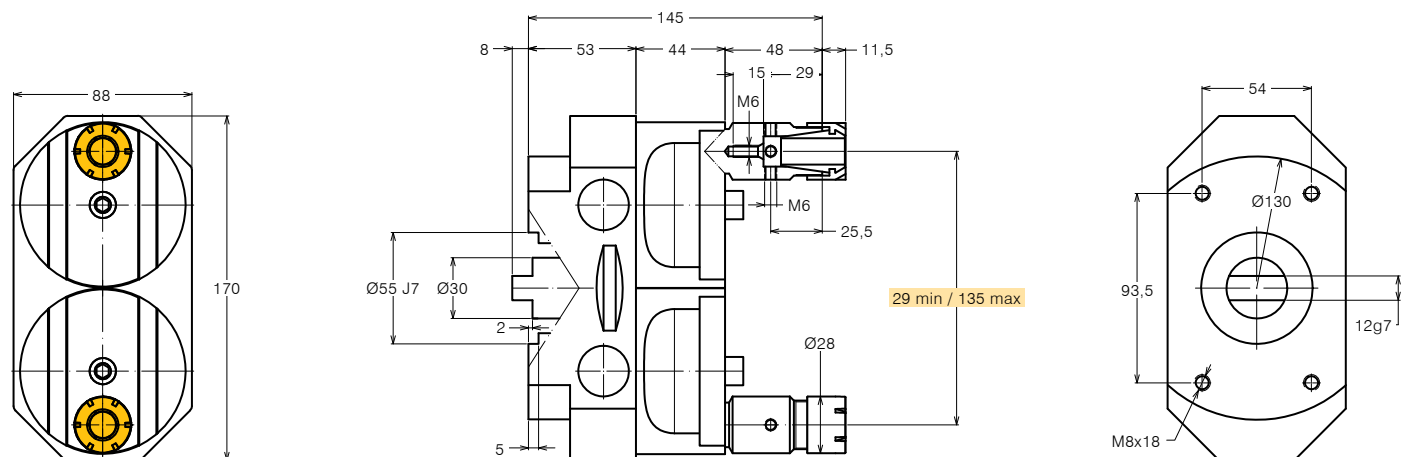



# TESTE MULTIMANDRINO AD INTERASSE REGISTRABILE MULTIPLE HEADS WITH ADJUSTABLE CENTRE DISTANCE

FORATURA  
DRILLING



MASCHIATURA  
TAPPING



## SPECIFICHE TECNICHE TECHNICAL FEATURES

Modello *Type* 823L Codice *Code* 111846.100

Mandrino porta-utensile per pinza <i>Tool-holder for collet</i>	<b>ER 20</b>
Rapporto di trasmissione <i>Transmission ratio</i>	1:1
Velocità max <i>Max speed</i>	3000 rpm
Potenza max mandrino <i>Spindle max power</i>	1.5 Kw
Carico assiale max <i>Max axial load</i>	1500 N
Peso <i>Weight</i>	4.9 Kg
Lubrificazione a grasso <i>Grease lubricated</i>	

## OPZIONI OPTIONS

Pinza ER20 DIN 6499/B <i>ER20 collet DIN 6499/B</i>	411220.100
Flangia di collegamento <i>Quill clamp</i>	410130.000
Trascinatore <i>Driver</i>	
Giunto <i>Joint</i>	
Chiave <i>Clamping wrench</i>	410220.000

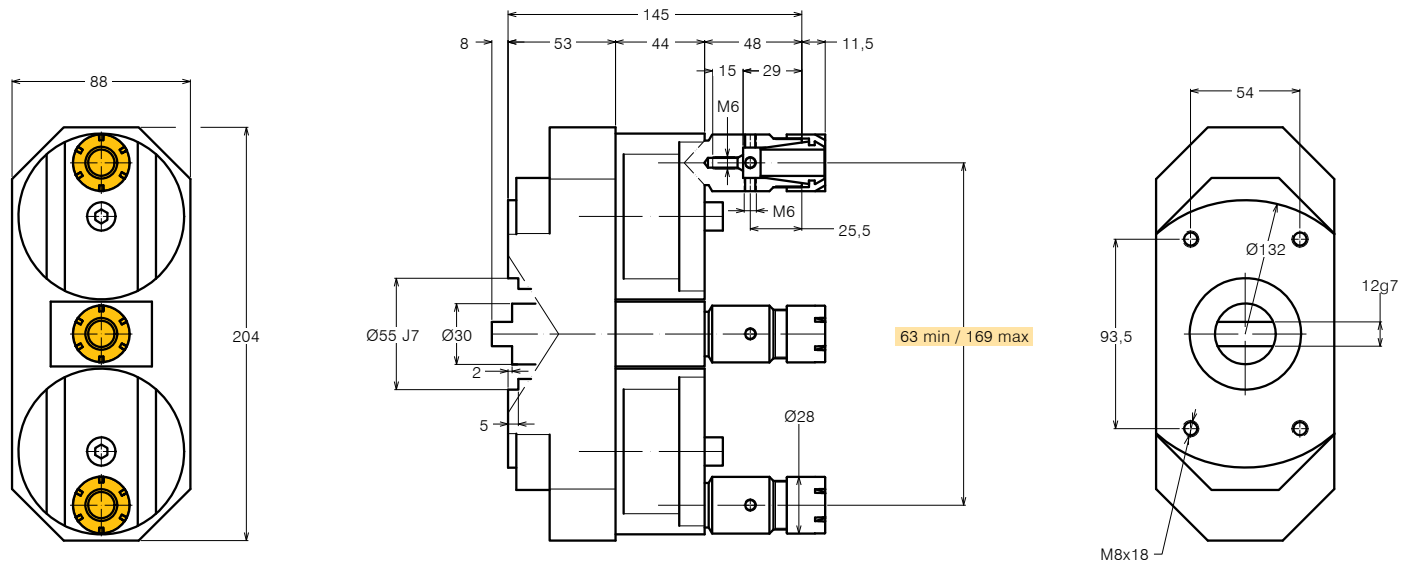

## SPECIFICHE TECNICHE TECHNICAL FEATURES

Modello *Type* 823 Codice *Code* 111845.100

Mandrino porta-utensile per pinza <i>Tool-holder for collet</i>	<b>ER 20</b>
Rapporto di trasmissione <i>Transmission ratio</i>	1:1
Velocità max <i>Max speed</i>	3000 rpm
Potenza max mandrino <i>Spindle max power</i>	1.5 Kw
Carico assiale max <i>Max axial load</i>	1500 N
Peso <i>Weight</i>	5.5 Kg
Lubrificazione a grasso <i>Grease lubricated</i>	

## OPZIONI OPTIONS

Pinza ER20 DIN 6499/B <i>ER20 collet DIN 6499/B</i>	411220.100
Flangia di collegamento <i>Quill clamp</i>	410130.000
Trascinatore <i>Driver</i>	
Giunto <i>Joint</i>	
Chiave <i>Clamping wrench</i>	410220.000

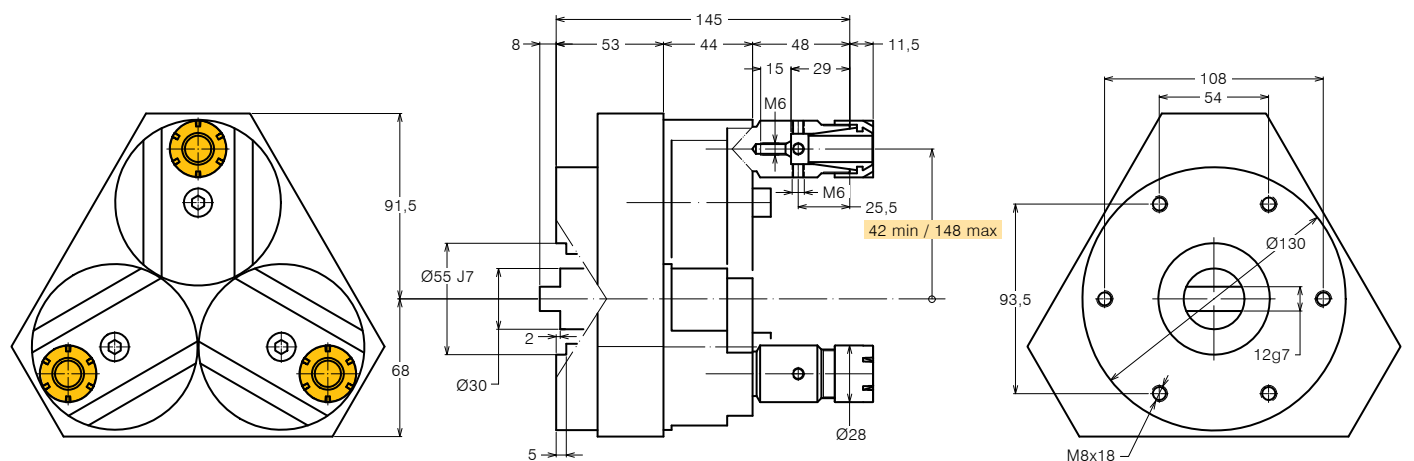



# TESTE MULTIMANDRINO AD INTERASSE REGISTRABILE MULTIPLE HEADS WITH ADJUSTABLE CENTRE DISTANCE

FORATURA  
DRILLING



MASCHIATURA  
TAPPING



## SPECIFICHE TECNICHE TECHNICAL FEATURES

Modello *Type* 824 Codice *Code* 111847.100

Mandrino porta-utensile per pinza <i>Tool-holder for collet</i>	<b>ER 20</b>
Rapporto di trasmissione <i>Transmission ratio</i>	1:1
Velocità max <i>Max speed</i>	3000 rpm
Potenza max mandrino <i>Spindle max power</i>	1.1 Kw
Carico assiale max <i>Max axial load</i>	1500 N
Peso <i>Weight</i>	7.5 Kg
Lubrificazione a grasso <i>Grease lubricated</i>	

## OPZIONI OPTIONS

Pinza ER20 DIN 6499/B <i>ER20 collet DIN 6499/B</i>	411220.100
Flangia di collegamento <i>Quill clamp</i>	410130.000
Trascinatore <i>Driver</i>	
Giunto <i>Joint</i>	
Chiave <i>Clamping wrench</i>	410220.000

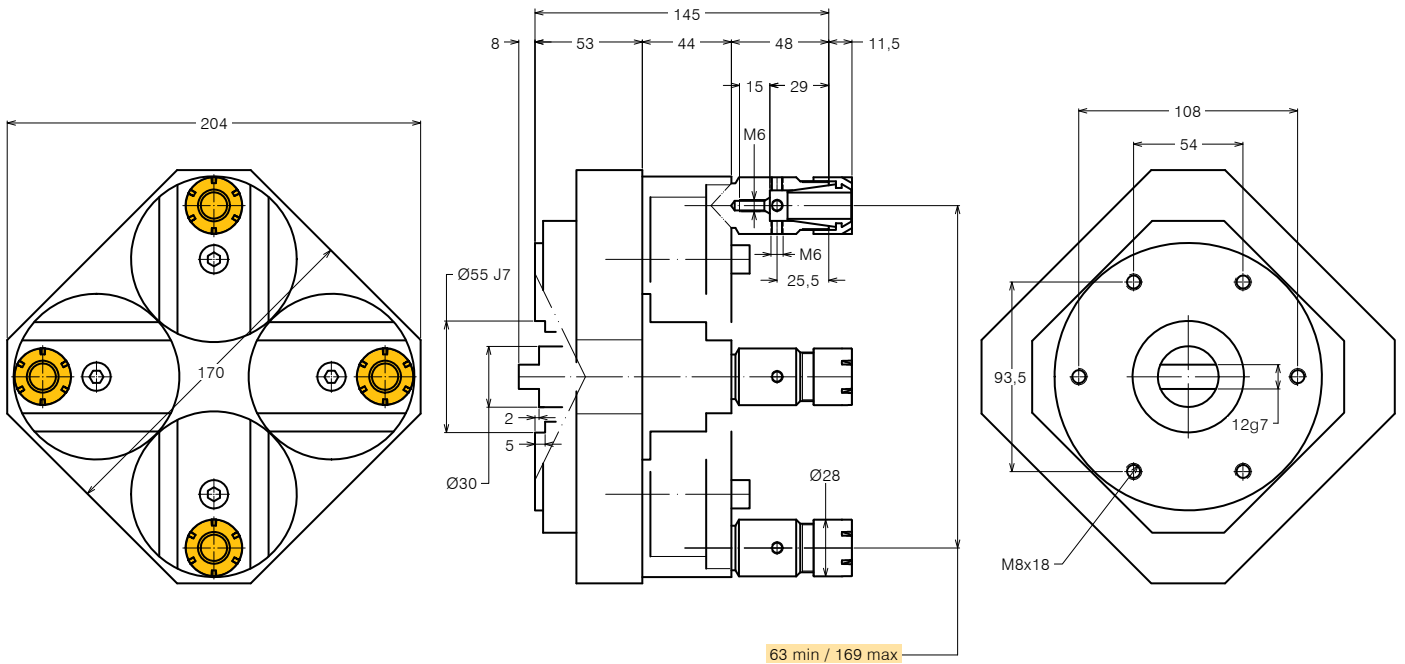



# TESTE MULTIMANDRINO AD INTERASSE REGISTRABILE MULTIPLE HEADS WITH ADJUSTABLE CENTRE DISTANCE

FORATURA  
DRILLING



MASCHIATURA  
TAPPING



## SPECIFICHE TECNICHE TECHNICAL FEATURES

Modello *Type* 824-extra sized      Codice *Code* 242082.100

Mandrino porta-utensile per pinza *Tool-holder for collet*      **ER 20**

Rapporto di trasmissione *Transmission ratio*      1:1

Velocità max *Max speed*      4000 rpm

Lubrificazione a grasso *Grease lubricated*

## OPZIONI OPTIONS

Pinza ER20 DIN 6499/B *ER20 collet DIN 6499/B*      411220.100

Flangia di collegamento *Quill clamp*

Trascinatore *Driver*

Giunto *Joint*

Chiave *Clamping wrench*      410220.000

