



## TESTE ANGOLARI REGISTRABILI ADJUSTABLE ANGLE HEADS

FORATURA  
DRILLING



MASCHIATURA  
TAPPING



### SPECIFICHE TECNICHE TECHNICAL FEATURES

Modello <i>Type</i>	T11-SK40	Codice <i>Code</i>	124980.100
Modello <i>Type</i>	T11-BT40	Codice <i>Code</i>	124942.100
Modello <i>Type</i>	T11-CAT40	Codice <i>Code</i>	124989.100
Modello <i>Type</i>	T11-HSK63	Codice <i>Code</i>	124981.100
Mandrino porta-utensile per pinza <i>Tool-holder for collet</i>	<b>ER 11</b>		
Rotazione cono <i>Input shank rotation</i>	SX / LH		
Rotazione mandrino <i>Output spindle rotation</i>	DX / RH		
Rapporto di trasmissione <i>Transmission ratio</i>	1:1		
Velocità max <i>Max speed</i>	12000 rpm		
Coppia <i>Torque</i>	5 Nm @ 500 rpm		
Carico assiale max <i>Max axial load</i>	300 N		
Peso <i>Weight</i>	4.1 Kg		
Lubrificazione a grasso <i>Grease lubricated</i>	Klüber Isoflex NBU 15		

### OPZIONI OPTIONS

Pinza ER11 DIN 6499/B <i>ER11 collet DIN 6499/B</i>	411211.100
Mandrino Weldon <i>Weldon spindle type</i>	
Perno antirotante interasse 80 mm <i>Stop-bar pin pitch 80 mm</i>	

### DOTAZIONE STANDARD STANDARD EQUIPMENT

Stop-block standard <i>Standard stop-block</i>	311201.025
Ghiera ER <i>ER nut</i>	
Chiave <i>Clamping wrench</i>	
Tubetto di grasso <i>Grease tube</i>	
Bauletto <i>Storage case</i>	

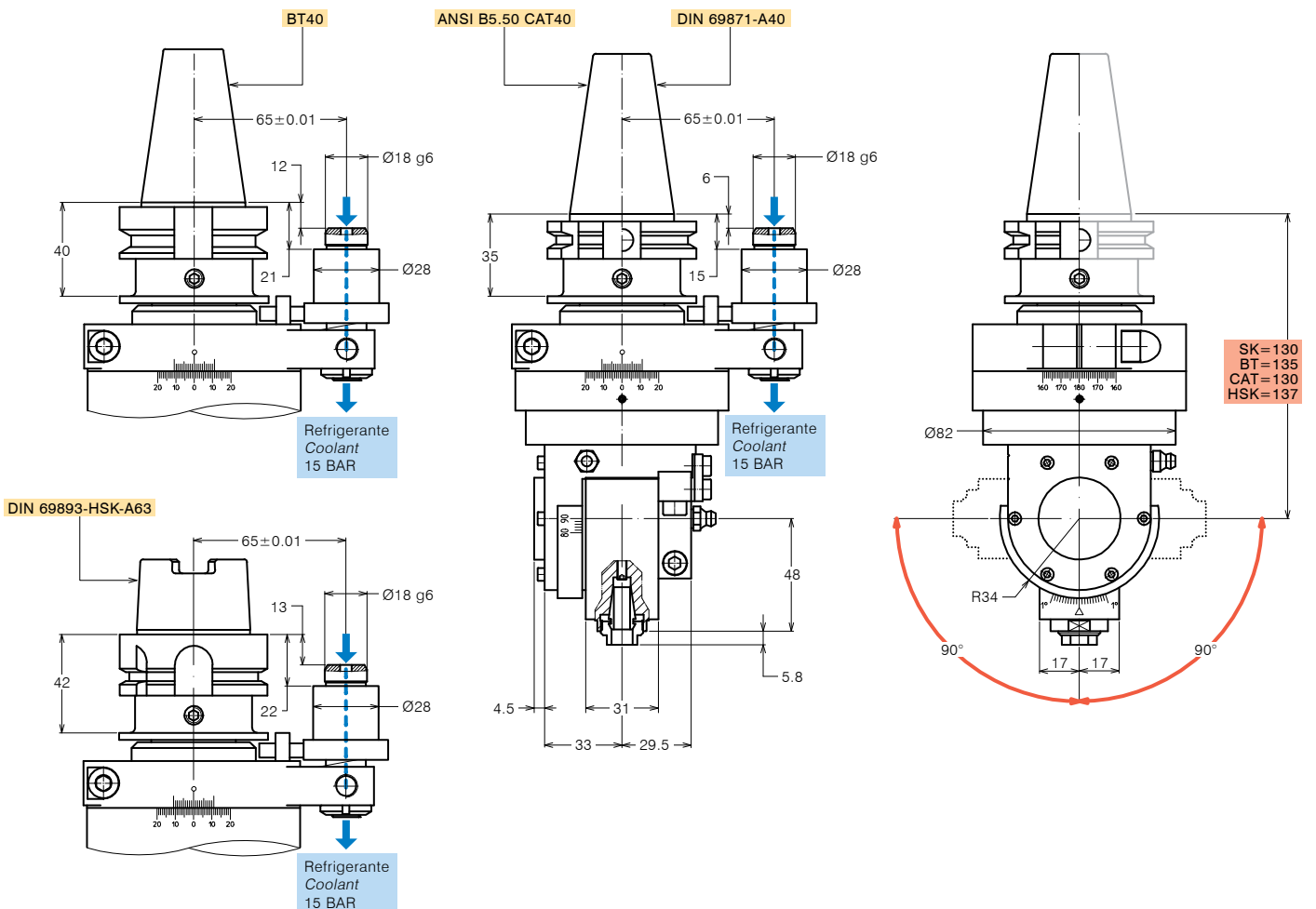



## TESTE ANGOLARI REGISTRABILI ADJUSTABLE ANGLE HEADS

FORATURA  
DRILLING

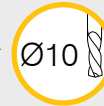

MASCHIATURA  
TAPPING



### SPECIFICHE TECNICHE TECHNICAL FEATURES

Modello <i>Type</i>	T16-SK40	Codice <i>Code</i>	124920.100
Modello <i>Type</i>	T16-BT40	Codice <i>Code</i>	124921.100
Modello <i>Type</i>	T16-CAT40	Codice <i>Code</i>	124990.100
Modello <i>Type</i>	T16-HSK63	Codice <i>Code</i>	124927.100
Mandrino porta-utensile per pinza <i>Tool-holder for collet</i>	<b>ER 16</b>		
Rotazione cono <i>Input shank rotation</i>	SX / LH		
Rotazione mandrino <i>Output spindle rotation</i>	DX / RH		
Rapporto di trasmissione <i>Transmission ratio</i>	1:1		
Velocità max <i>Max speed</i>	12000 rpm		
Coppia <i>Torque</i>	12m @ 500 rpm		
Carico assiale max <i>Max axial load</i>	350 N		
Peso <i>Weight</i>	4 Kg		
Lubrificazione a grasso <i>Grease lubricated</i>	Klüber Isoflex NBU 15		

### OPZIONI OPTIONS

Pinza ER16 DIN 6499/B <i>ER16 collet DIN 6499/B</i>	411216.100
Pinza di maschiatura ET-1-16 con compensazione <i>Tapping collet ET-1-16 with compensation</i>	401216.200
Pinza di maschiatura ER16 con quadro <i>Tapping collet ER16 with square</i>	411216.200
Mandrino Weldon <i>Weldon spindle type</i>	
Perno antirotante interasse 80 mm <i>Stop-bar pin pitch 80 mm</i>	

### DOTAZIONE STANDARD STANDARD EQUIPMENT

Stop-block standard <i>Standard stop-block</i>	311201.025
Ghiera ER <i>ER nut</i>	
Chiave <i>Clamping wrench</i>	
Tubetto di grasso <i>Grease tube</i>	
Bauetto <i>Storage case</i>	

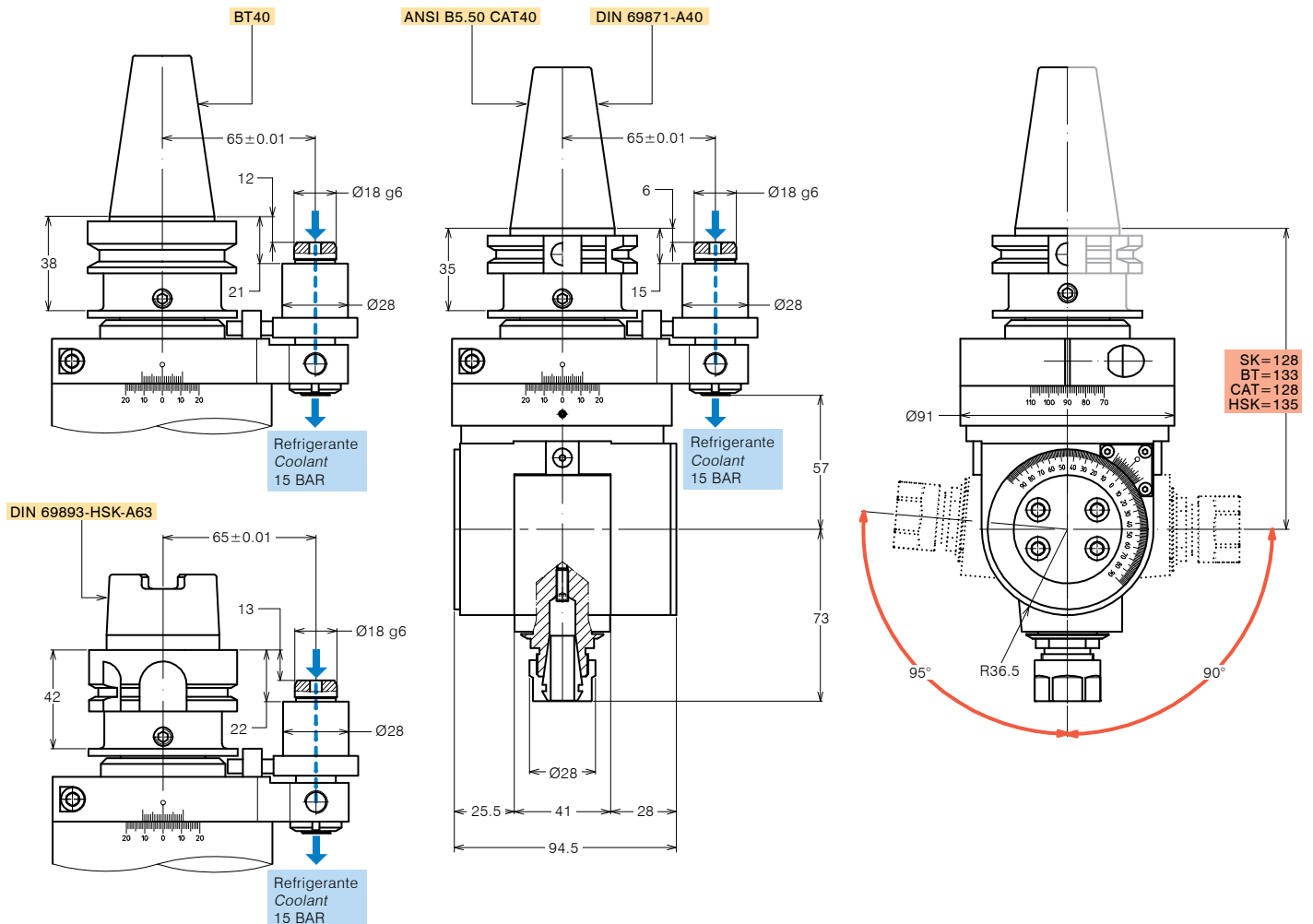



## TESTE ANGOLARI REGISTRABILI ADJUSTABLE ANGLE HEADS

FORATURA  
DRILLING

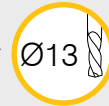

MASCHIATURA  
TAPPING



### SPECIFICHE TECNICHE TECHNICAL FEATURES

Modello <i>Type</i>	T20-SK40	Codice <i>Code</i>	124936.100
Modello <i>Type</i>	T20-BT40	Codice <i>Code</i>	124937.100
Modello <i>Type</i>	T20-CAT40	Codice <i>Code</i>	124986.100
Modello <i>Type</i>	T20-HSK63	Codice <i>Code</i>	124951.100
Mandrino porta-utensile per pinza <i>Tool-holder for collet</i>	<b>ER 20</b>		
Rotazione cono <i>Input shank rotation</i>	SX / LH		
Rotazione mandrino <i>Output spindle rotation</i>	DX / RH		
Rapporto di trasmissione <i>Transmission ratio</i>	1:1		
Velocità max <i>Max speed</i>	12000 rpm		
Coppia <i>Torque</i>	13 Nm @ 500 rpm		
Carico assiale max <i>Max axial load</i>	350 N		
Peso <i>Weight</i>	5 Kg		
Lubrificazione a grasso <i>Grease lubricated</i>	Klüber Isoflex NBU 15		

### OPZIONI OPTIONS

Pinza ER20 DIN 6499/B <i>ER20 collet DIN 6499/B</i>	411220.100
Pinza di maschiatura ET-1-20 con compensazione <i>Tapping collet ET-1-20 with compensation</i>	401220.200
Pinza di maschiatura ER20 con quadro <i>Tapping collet ER20 with square</i>	411220.200
Mandrino Weldon <i>Weldon spindle type</i>	
Mandrino ABS licenza Komet® <i>ABS license Komet® spindle type</i>	
Perno antirotante interasse 80 mm <i>Stop-bar pin pitch 80 mm</i>	

### DOTAZIONE STANDARD STANDARD EQUIPMENT

Stop-block standard <i>Standard stop-block</i>	311201.025
Ghiera ER <i>ER nut</i>	
Chiave <i>Clamping wrench</i>	
Tubetto di grasso <i>Grease tube</i>	
Bauletto <i>Storage case</i>	

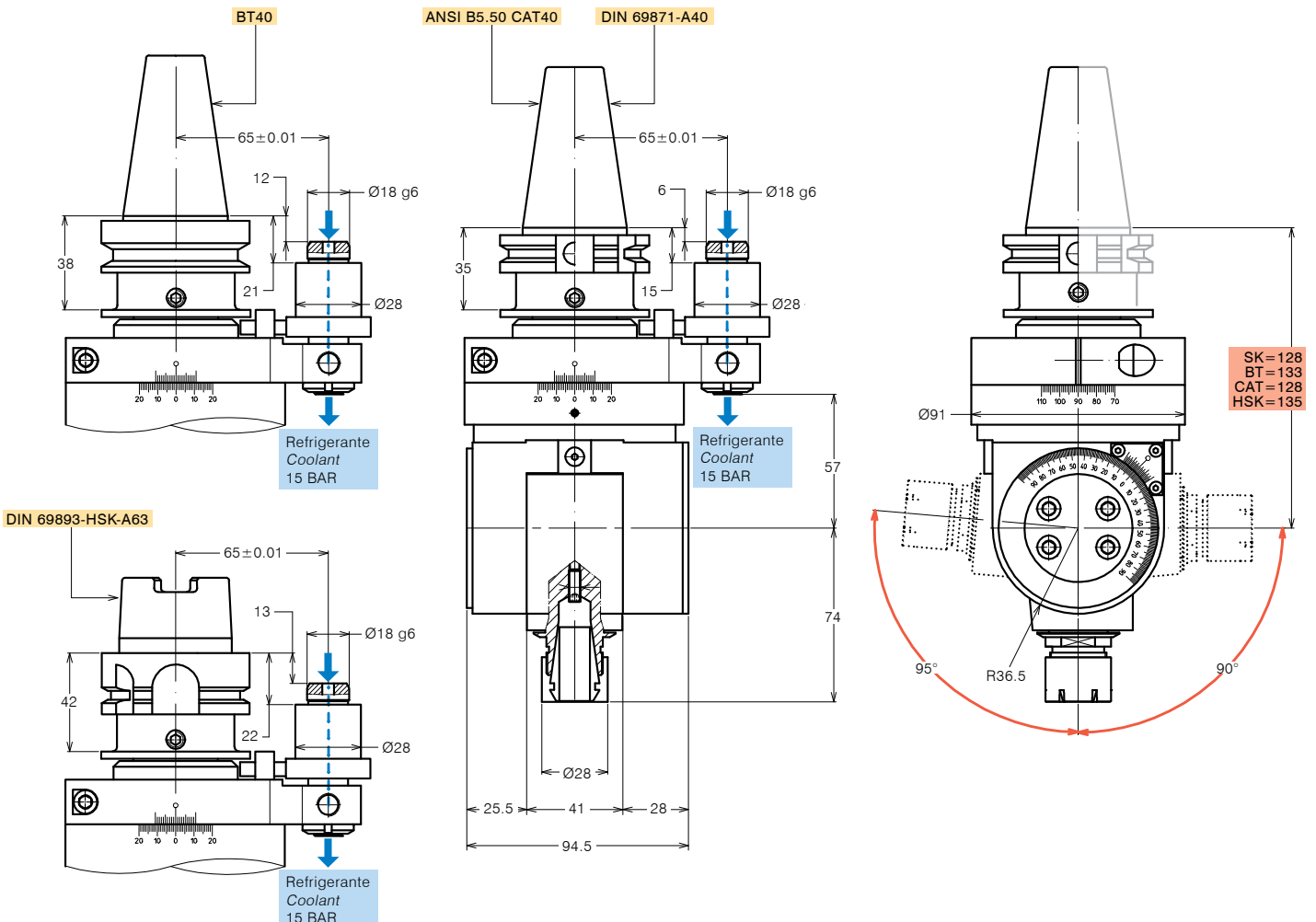



## TESTE ANGOLARI REGISTRABILI ADJUSTABLE ANGLE HEADS

FORATURA  
DRILLING



MASCHIATURA  
TAPPING



### SPECIFICHE TECNICHE TECHNICAL FEATURES

Modello <i>Type</i>	T25-SK40	Codice <i>Code</i>	124961.100
Modello <i>Type</i>	T25-BT40	Codice <i>Code</i>	124962.100
Modello <i>Type</i>	T25-CAT40	Codice <i>Code</i>	124963.100
Modello <i>Type</i>	T25-HSK63	Codice <i>Code</i>	124964.100
Mandrino porta-utensile per pinza <i>Tool-holder for collet</i>	<b>ER 25</b>		
Rotazione cono <i>Input shank rotation</i>	SX / LH		
Rotazione mandrino <i>Output spindle rotation</i>	DX / RH		
Rapporto di trasmissione <i>Transmission ratio</i>	1:1		
Velocità max <i>Max speed</i>	6000 rpm		
Coppia <i>Torque</i>	14 Nm @ 500 rpm		
Carico assiale max <i>Max axial load</i>	500 N		
Peso <i>Weight</i>	5 Kg		
Lubrificazione a grasso <i>Grease lubricated</i>	Klüber Isoflex NBU 15		

### OPZIONI OPTIONS

Pinza ER25 DIN 6499/B <i>ER25 collet DIN 6499/B</i>	411225.100
Pinza di maschiatura ET-1-25 con compensazione <i>Tapping collet ET-1-25 with compensation</i>	401225.200
Pinza di maschiatura ER25 con quadro <i>Tapping collet ER25 with square</i>	411225.200
Mandrino Weldon <i>Weldon spindle type</i>	
Mandrino ABS licenza Komet® <i>ABS license Komet® spindle type</i>	
Mandrino DIN 69893-HSK <i>DIN 69893-HSK spindle type</i>	
Perno antirotante interasse 80 mm <i>Stop-bar pin pitch 80 mm</i>	

### DOTAZIONE STANDARD STANDARD EQUIPMENT

Stop-block standard <i>Standard stop-block</i>	311201.025
Ghiera ER <i>ER nut</i>	
Chiave <i>Clamping wrench</i>	
Tubetto di grasso <i>Grease tube</i>	
Bauletto <i>Storage case</i>	

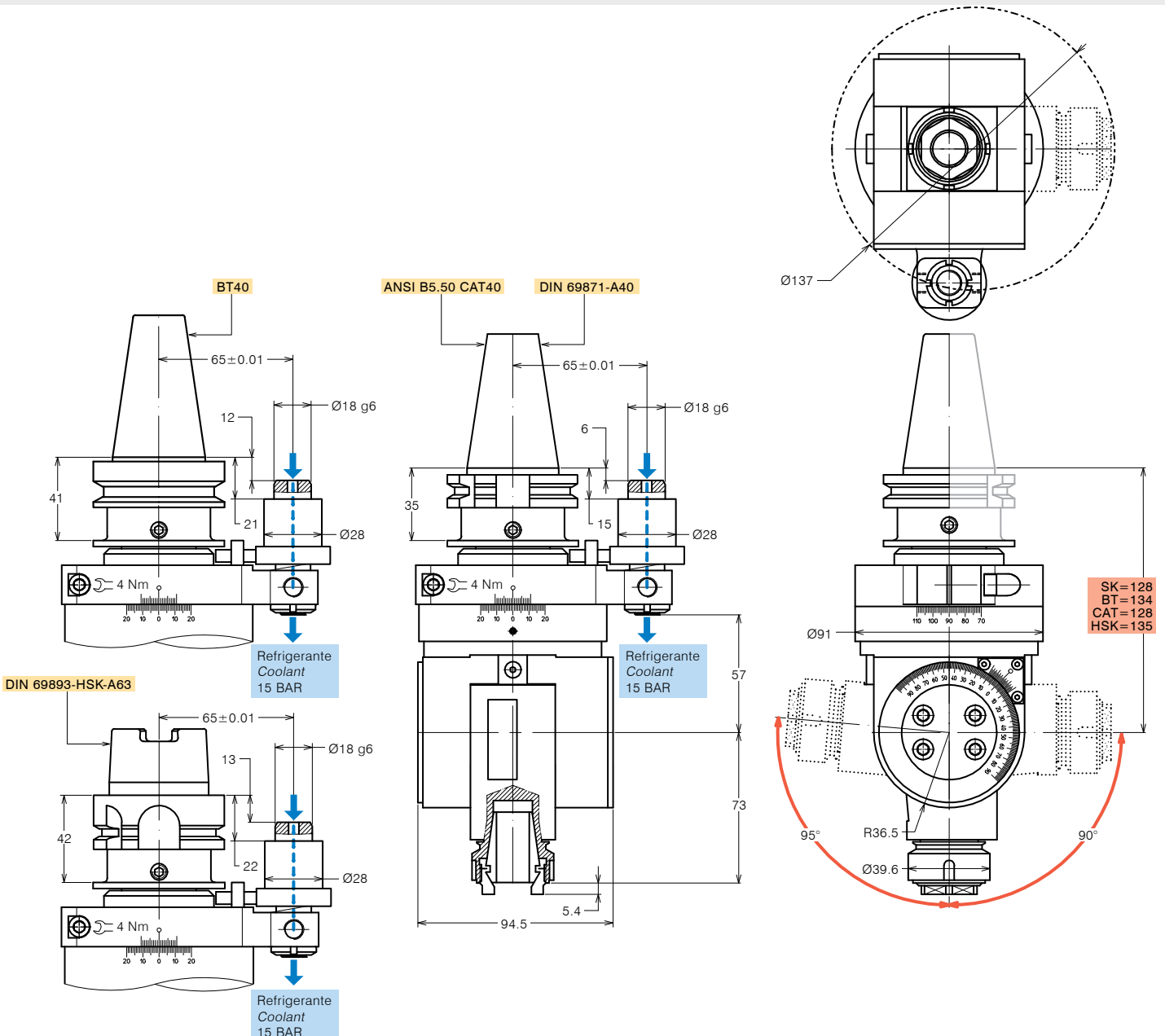



## TESTE ANGOLARI REGISTRABILI ADJUSTABLE ANGLE HEADS

FORATURA  
DRILLING



MASCHIATURA  
TAPPING



REFRIGERANTE  
COOLANT



### SPECIFICHE TECNICHE TECHNICAL FEATURES

Modello *Type* T25R-SK40R Codice *Code* 1249143.100

Modello *Type* T25R-BT40R Codice *Code* 1249144.100

Modello *Type* T25R-CAT40R Codice *Code* 1249145.100

Modello *Type* T25R-HSK63R Codice *Code* 1249146.100

Mandrino porta-utensile per pinza *Tool-holder for collet* **ER 25**

Rotazione cono *Input shank rotation* SX / LH

Rotazione mandrino *Output spindle rotation* DX / RH

Rapporto di trasmissione *Transmission ratio* 1:1

Velocità max *Max speed* 6000 rpm

Coppia *Torque* 37 Nm @ 500 rpm

Carico assiale max *Max axial load* 650 N

Peso *Weight* 6.5 Kg

Lubrificazione a grasso *Grease lubricated* Klüber Isoflex NBU 15

### OPZIONI OPTIONS

Pinza ER25 DIN 6499/B *ER25 collet DIN 6499/B* 411225.100

Pinza di maschiatura ET-1-25 con compensazione 401225.200

*Tapping collet ET-1-25 with compensation*

Pinza di maschiatura ER25 con quadro 411225.200

*Tapping collet ER25 with square*

Mandrino Weldon *Weldon spindle type*

Mandrino ABS licenza Komet®

*ABS license Komet® spindle type*

Mandrino DIN 69893-HSK

*DIN 69893-HSK spindle type*

Perno antirotante interasse 80 mm

*Stop-bar pin pitch 80 mm*

### DOTAZIONE STANDARD STANDARD EQUIPMENT

Stop-block standard *Standard stop-block* 311201.025

Ghiera ER *ER nut*

Chiave *Clamping wrench*

Tubetto di grasso *Grease tube*

Bauletto *Storage case*

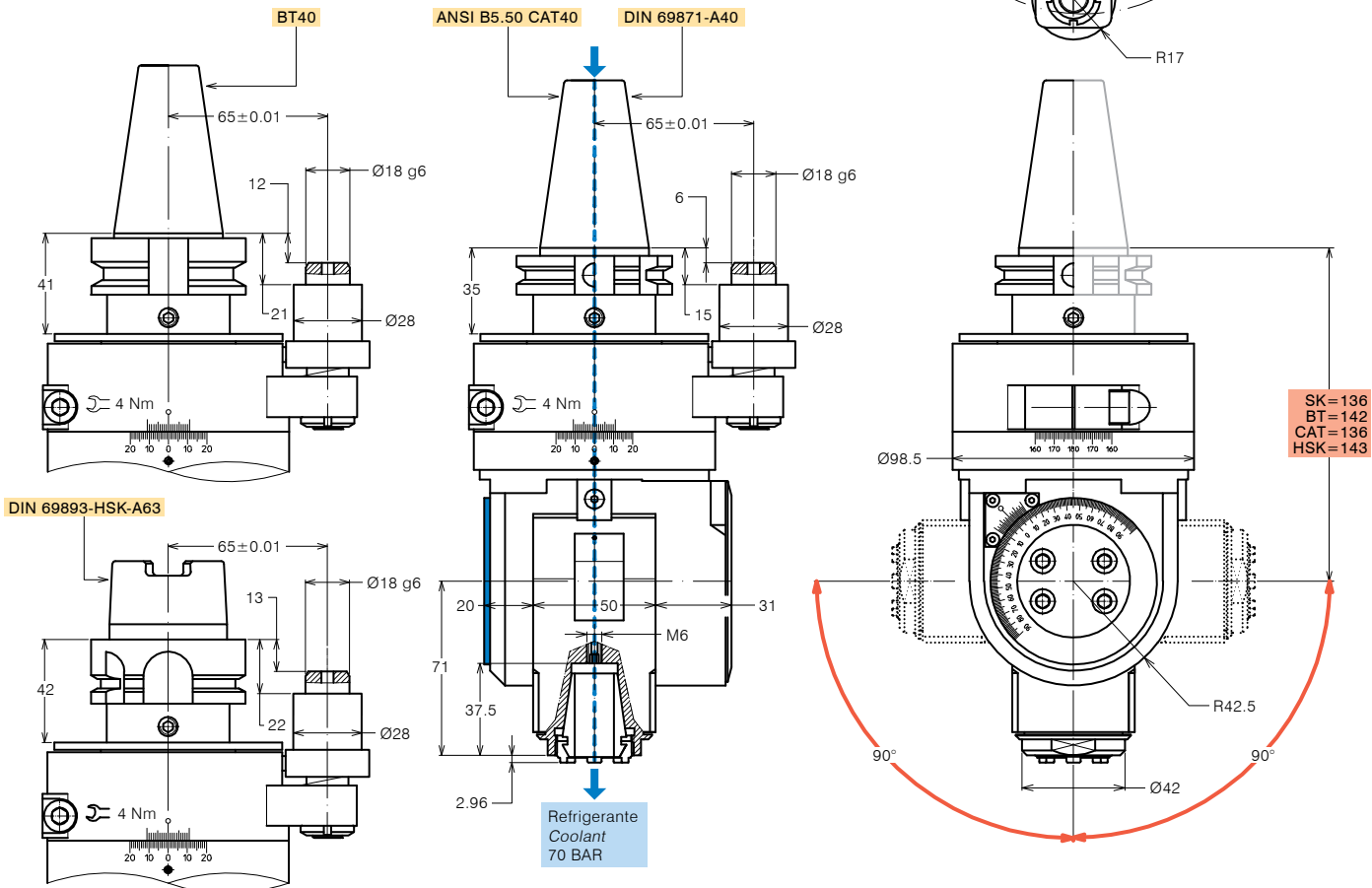



## TESTE ANGOLARI REGISTRABILI ADJUSTABLE ANGLE HEADS

FORATURA  
DRILLING



MASCHIATURA  
TAPPING



REFRIGERANTE  
COOLANT



### SPECIFICHE TECNICHE TECHNICAL FEATURES

Modello <i>Type</i>	T25R-SK40	Codice <i>Code</i>	1249147.100
Modello <i>Type</i>	T25R-BT40	Codice <i>Code</i>	1249148.100
Modello <i>Type</i>	T25R-CAT40	Codice <i>Code</i>	1249149.100
Modello <i>Type</i>	T25R-HSK63	Codice <i>Code</i>	1249150.100
Mandrino porta-utensile per pinza <i>Tool-holder for collet</i>	<b>ER 25</b>		
Rotazione cono <i>Input shank rotation</i>	SX / LH		
Rotazione mandrino <i>Output spindle rotation</i>	DX / RH		
Rapporto di trasmissione <i>Transmission ratio</i>	1:1		
Velocità max <i>Max speed</i>	6000 rpm		
Coppia <i>Torque</i>	37 Nm @ 500 rpm		
Carico assiale max <i>Max axial load</i>	650 N		
Peso <i>Weight</i>	6.5 Kg		
Lubrificazione a grasso <i>Grease lubricated</i>	Klüber Isoflex NBU 15		

### OPZIONI OPTIONS

Pinza ER25 DIN 6499/B <i>ER25 collet DIN 6499/B</i>	411225.100
Pinza di maschiatura ET-1-25 con compensazione <i>Tapping collet ET-1-25 with compensation</i>	401225.200
Pinza di maschiatura ER25 con quadro <i>Tapping collet ER25 with square</i>	411225.200
Mandrino Weldon <i>Weldon spindle type</i>	
Mandrino ABS licenza Komet® <i>ABS license Komet® spindle type</i>	
Mandrino DIN 69893-HSK <i>DIN 69893-HSK spindle type</i>	
Perno antirotante interasse 80 mm <i>Stop-bar pin pitch 80 mm</i>	

### DOTAZIONE STANDARD STANDARD EQUIPMENT

Stop-block standard <i>Standard stop-block</i>	311201.025
Ghiera ER <i>ER nut</i>	
Chiave <i>Clamping wrench</i>	
Tubetto di grasso <i>Grease tube</i>	
Bauletto <i>Storage case</i>	

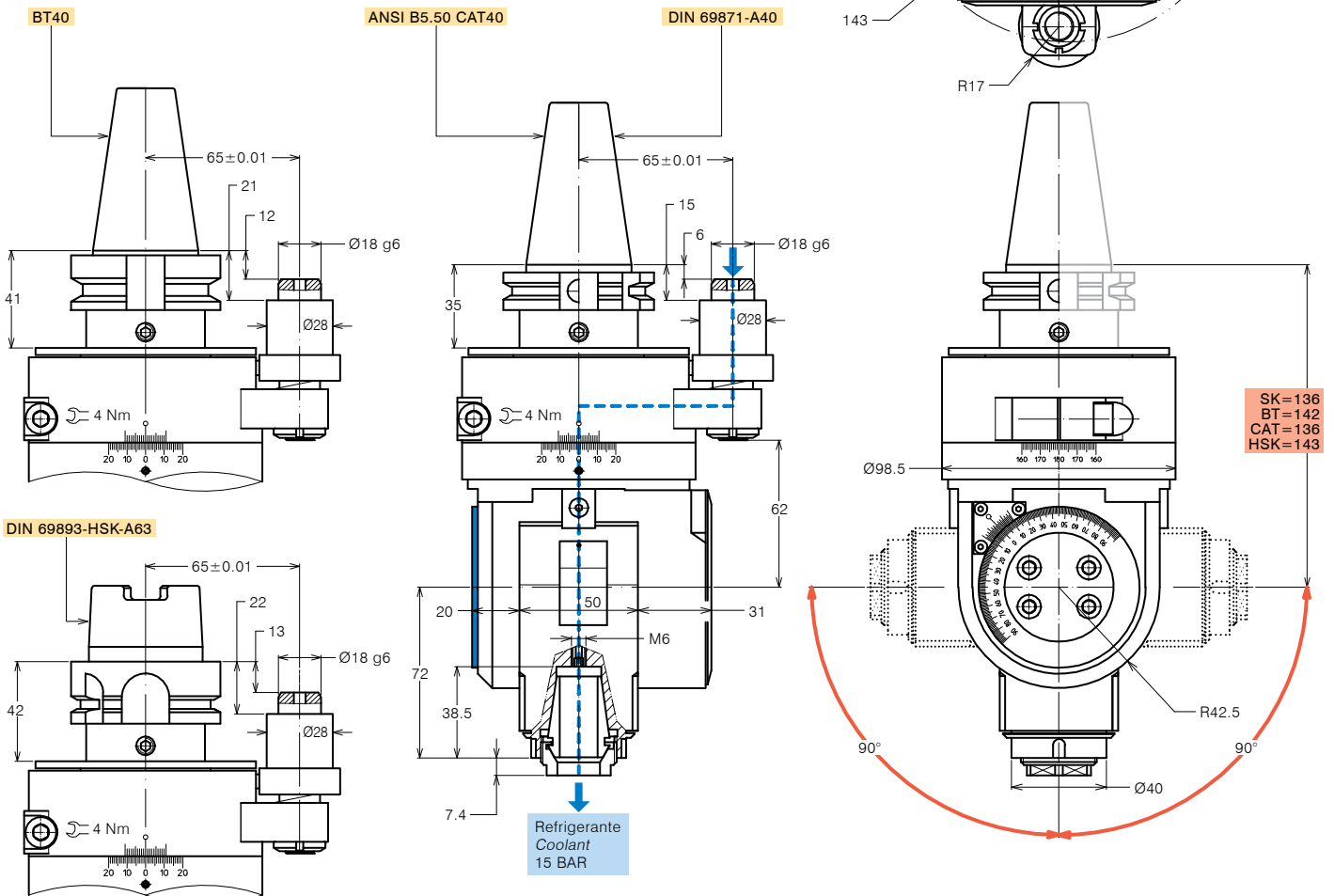



## TESTE ANGOLARI REGISTRABILI ADJUSTABLE ANGLE HEADS

FORATURA  
DRILLING



MASCHIATURA  
TAPPING



### SPECIFICHE TECNICHE TECHNICAL FEATURES

Modello <i>Type</i>	T25-SK50	Codice <i>Code</i>	124907.100
Modello <i>Type</i>	T25-BT50	Codice <i>Code</i>	124913.100
Modello <i>Type</i>	T25-CAT50	Codice <i>Code</i>	124991.100
Modello <i>Type</i>	T25-HSK100	Codice <i>Code</i>	124952.100
Mandrino porta-utensile per pinza <i>Tool-holder for collet</i>	<b>ER 25</b>		
Rotazione cono <i>Input shank rotation</i>	DX / RH		
Rotazione mandrino <i>Output spindle rotation</i>	DX / RH		
Rapporto di trasmissione <i>Transmission ratio</i>	1:1		
Velocità max <i>Max speed</i>	6000 rpm		
Coppia <i>Torque</i>	27 Nm @ 500 rpm		
Carico assiale max <i>Max axial load</i>	1000 N		
Peso <i>Weight</i>	13 Kg		
Lubrificazione a grasso <i>Grease lubricated</i>	Klüber Isoflex NBU 15		

### OPZIONI OPTIONS

Pinza ER25 DIN 6499/B <i>ER25 collet DIN 6499/B</i>	411225.100
Pinza di maschiatura ET-1-25 con compensazione <i>Tapping collet ET-1-25 with compensation</i>	401225.200
Pinza di maschiatura ER25 con quadro <i>Tapping collet ER25 with square</i>	411225.200
Mandrino Weldon <i>Weldon spindle type</i>	
Mandrino ABS licenza Komet® <i>ABS license Komet® spindle type</i>	
Mandrino DIN 69893-HSK <i>DIN 69893-HSK spindle type</i>	
Perno antirotante interasse 110 mm <i>Stop-bar pin pitch 110 mm</i>	

### DOTAZIONE STANDARD STANDARD EQUIPMENT

Stop-block standard <i>Standard stop-block</i>	311201.025
Ghiera ER <i>ER nut</i>	
Chiave <i>Clamping wrench</i>	
Tubetto di grasso <i>Grease tube</i>	
Bauletto <i>Storage case</i>	

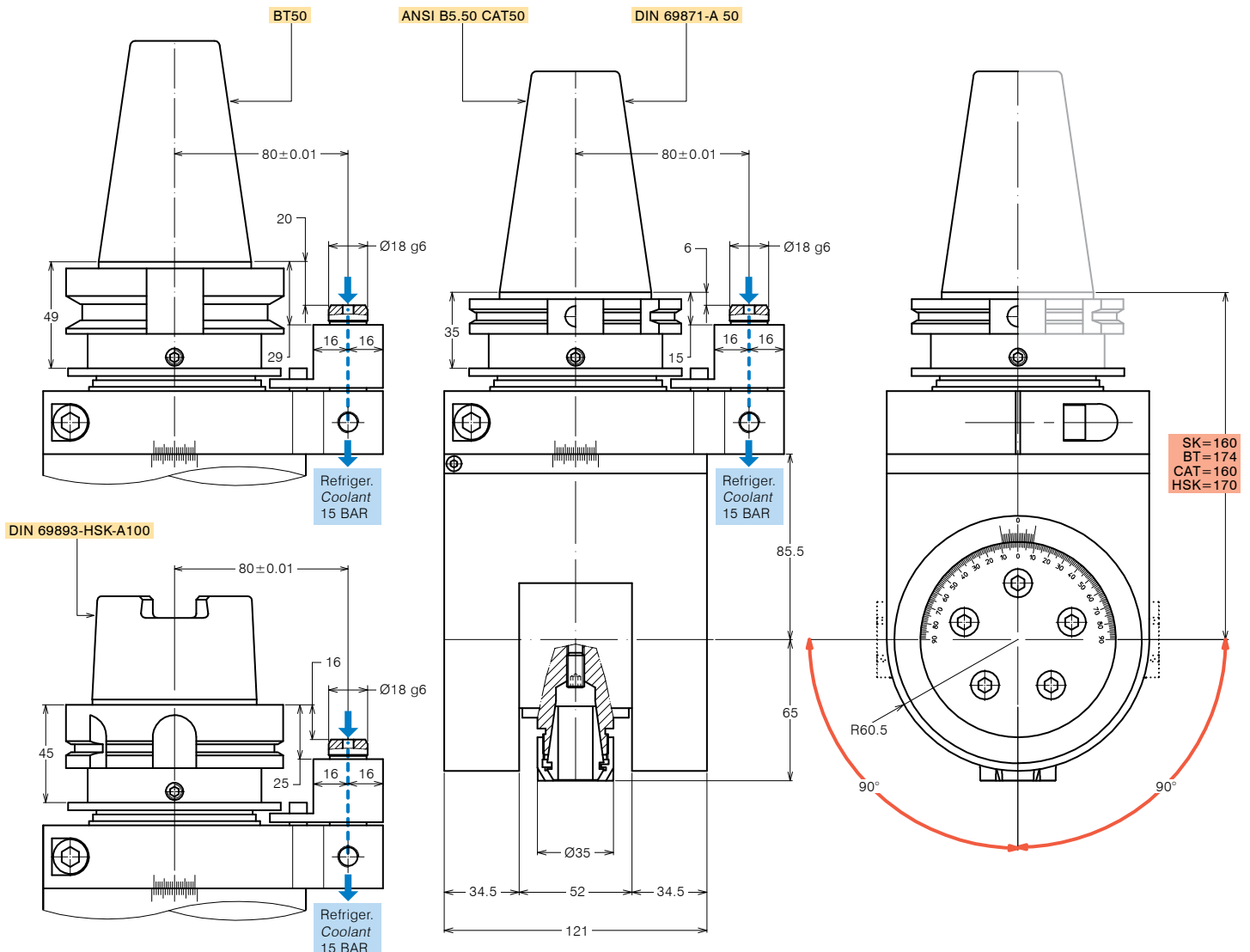



## TESTE ANGOLARI REGISTRABILI ADJUSTABLE ANGLE HEADS

FORATURA  
DRILLING



MASCHIATURA  
TAPPING



### SPECIFICHE TECNICHE TECHNICAL FEATURES

Modello <i>Type</i>	T32-SK50	Codice <i>Code</i>	124910.100
Modello <i>Type</i>	T32-BT50	Codice <i>Code</i>	124914.100
Modello <i>Type</i>	T32-CAT50	Codice <i>Code</i>	124987.100
Modello <i>Type</i>	T32-HSK100	Codice <i>Code</i>	124930.100
Mandrino porta-utensile per pinza <i>Tool-holder for collet</i>	<b>ER 32</b>		
Rotazione cono <i>Input shank rotation</i>	DX / RH		
Rotazione mandrino <i>Output spindle rotation</i>	DX / RH		
Rapporto di trasmissione <i>Transmission ratio</i>	1:1		
Velocità max <i>Max speed</i>	5000 rpm		
Coppia <i>Torque</i>	50 Nm @ 500 rpm		
Carico assiale max <i>Max axial load</i>	1200 N		
Peso <i>Weight</i>	17 Kg		
Lubrificazione a grasso <i>Grease lubricated</i>	Klüber Isoflex NBU 15		

### OPZIONI OPTIONS

Pinza ER32 DIN 6499/B <i>ER32 collet DIN 6499/B</i>	411232.100
Pinza di maschiatura ET-1-32 con compensazione <i>Tapping collet ET-1-32 with compensation</i>	401232.200
Pinza di maschiatura ER32 con quadro <i>Tapping collet ER32 with square</i>	411232.200
Mandrino Weldon <i>Weldon spindle type</i>	
Mandrino ABS licenza Komet® <i>ABS license Komet® spindle type</i>	
Mandrino DIN 69893-HSK <i>DIN 69893-HSK spindle type</i>	
Perno antirotante interasse 110 mm <i>Stop-bar pin pitch 110 mm</i>	

### DOTAZIONE STANDARD STANDARD EQUIPMENT

Stop-block standard <i>Standard stop-block</i>	311201.025
Ghiera ER <i>ER nut</i>	
Chiave <i>Clamping wrench</i>	
Tubetto di grasso <i>Grease tube</i>	
Bauletto <i>Storage case</i>	

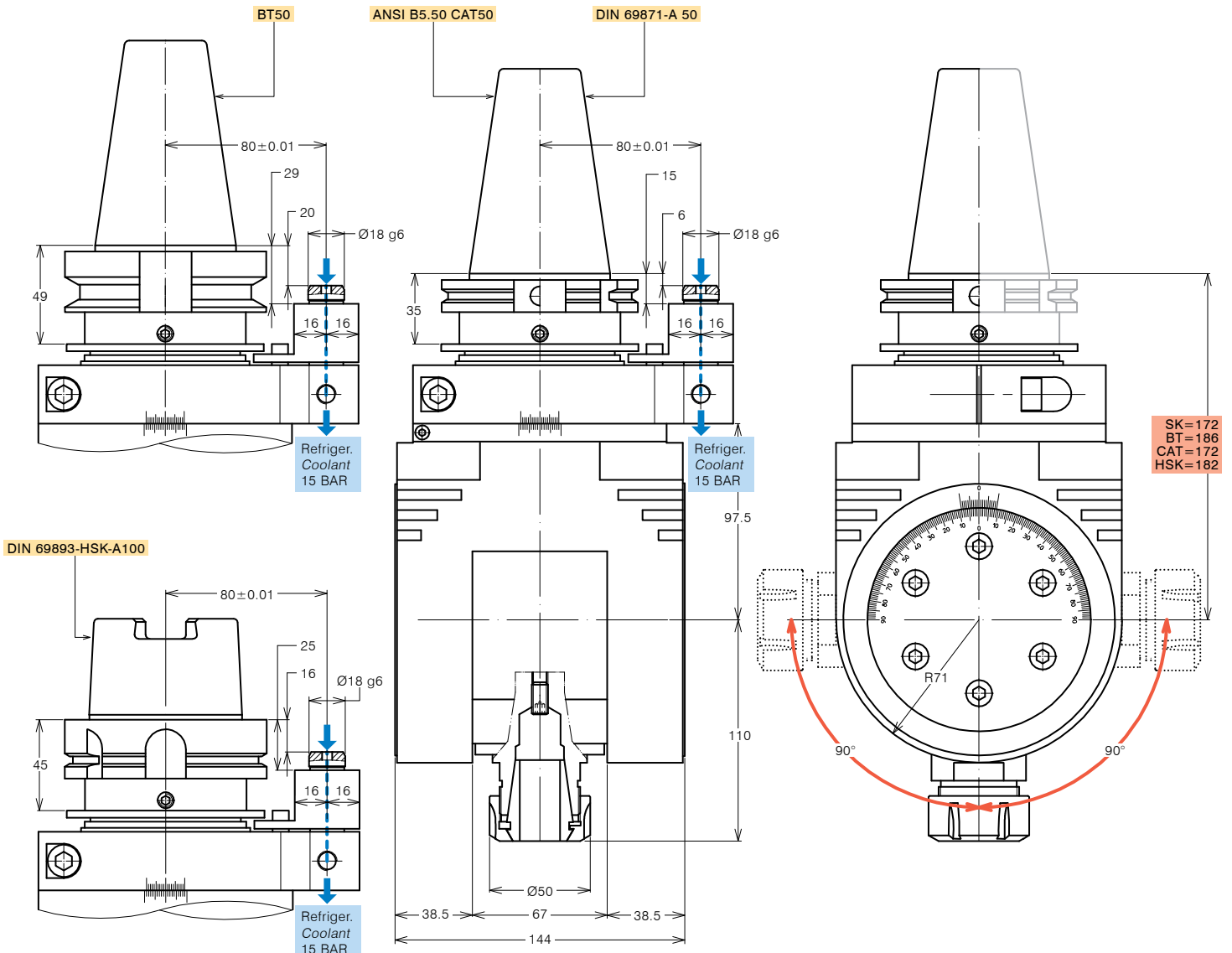





## TESTE ANGOLARI REGISTRABILI ADJUSTABLE ANGLE HEADS

FORATURA  
DRILLING



MASCHIATURA  
TAPPING



REFRIGERANTE  
COOLANT



### SPECIFICHE TECNICHE TECHNICAL FEATURES

Modello <i>Type</i>	T32-SK50-R	Codice <i>Code</i>	1249123.100
Modello <i>Type</i>	T32-BT50-R	Codice <i>Code</i>	1249124.100
Modello <i>Type</i>	T32-CAT50-R	Codice <i>Code</i>	1249125.100
Modello <i>Type</i>	T32-HSK100-R	Codice <i>Code</i>	1249126.100
Mandrino porta-utensile per pinza <i>Tool-holder for collet</i>	<b>ER 32</b>		
Rotazione cono <i>Input shank rotation</i>	SX / LH		
Rotazione mandrino <i>Output spindle rotation</i>	DX / RH		
Rapporto di trasmissione <i>Transmission ratio</i>	1:1		
Velocità max <i>Max speed</i>	3500 rpm		
Coppia <i>Torque</i>	50 Nm @ 500 rpm		
Carico assiale max <i>Max axial load</i>	1700 N		
Peso <i>Weight</i>	18 Kg		
Lubrificazione a grasso <i>Grease lubricated</i>	Klüber Isoflex NBU 15		

### OPZIONI OPTIONS

Pinza ER32 DIN 6499/B <i>ER32 collet DIN 6499/B</i>	411232.100
Pinza di maschiatura ET-1-32 con compensazione <i>Tapping collet ET-1-32 with compensation</i>	401232.200
Pinza di maschiatura ER32 con quadro <i>Tapping collet ER32 with square</i>	411232.200
Mandrino Weldon <i>Weldon spindle type</i>	
Mandrino ABS licenza Komet® <i>ABS license Komet® spindle type</i>	
Mandrino DIN 69893-HSK <i>DIN 69893-HSK spindle type</i>	
Perno antirotante interasse 110 mm <i>Stop-bar pin pitch 110 mm</i>	

### DOTAZIONE STANDARD STANDARD EQUIPMENT

Stop-block standard <i>Standard stop-block</i>	311201.026
Ghiera ER <i>ER nut</i>	
Chiave <i>Clamping wrench</i>	
Tubetto di grasso <i>Grease tube</i>	
Bauletto <i>Storage case</i>	

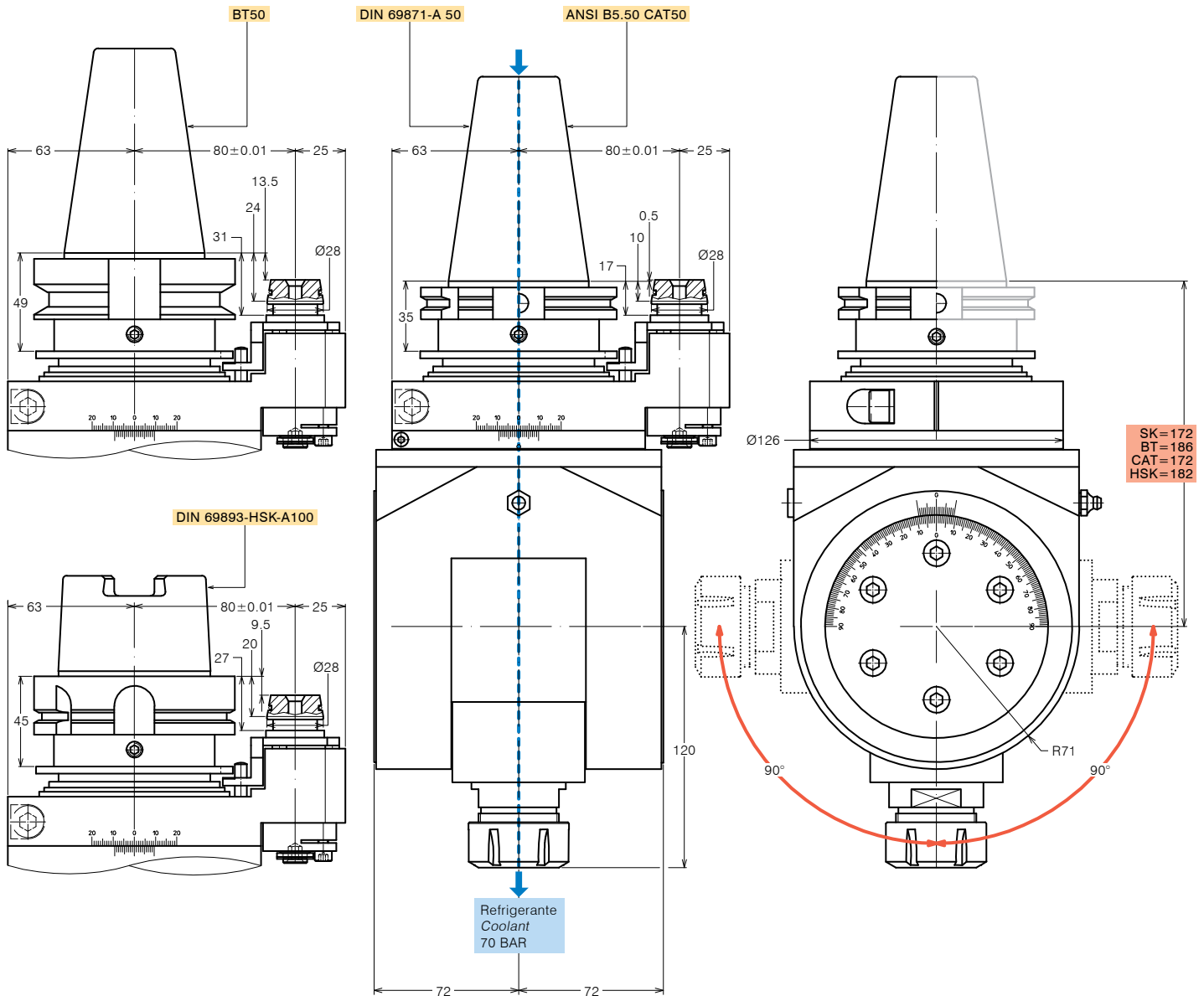



## TESTE ANGOLARI REGISTRABILI ADJUSTABLE ANGLE HEADS

FORATURA  
DRILLING



MASCHIATURA  
TAPPING



### SPECIFICHE TECNICHE TECHNICAL FEATURES

Modello <i>Type</i>	T40-SK50	Codice <i>Code</i>	124965.100.80
Modello <i>Type</i>	T40-BT50	Codice <i>Code</i>	124966.100.80
Modello <i>Type</i>	T40-CAT50	Codice <i>Code</i>	124967.100.80
Modello <i>Type</i>	T40-HSK100	Codice <i>Code</i>	124968.100.80
Mandrino porta-utensile per pinza <i>Tool-holder for collet</i>	<b>ER 40</b>		
Rotazione cono <i>Input shank rotation</i>	DX / RH		
Rotazione mandrino <i>Output spindle rotation</i>	DX / RH		
Rapporto di trasmissione <i>Transmission ratio</i>	1:1		
Velocità max <i>Max speed</i>	3500 rpm		
Coppia <i>Torque</i>	55 Nm at 500 rpm		
Carico assiale max <i>Max axial load</i>	1200 N		
Peso <i>Weight</i>	17 Kg		
Lubrificazione a grasso <i>Grease lubricated</i>	Klüber Isoflex NBU 15		

### OPZIONI OPTIONS

Pinza ER40 DIN 6499/B <i>ER40 collet DIN 6499/B</i>	411240.100
Pinza di maschiatura ET-1-40 con compensazione <i>Tapping collet ET-1-40 with compensation</i>	401240.200
Pinza di maschiatura ER40 con quadro <i>Tapping collet ER40 with square</i>	411240.200
Mandrino Weldon <i>Weldon spindle type</i>	
Mandrino ABS licenza Komet® <i>ABS license Komet® spindle type</i>	
Mandrino DIN 69893-HSK <i>DIN 69893-HSK spindle type</i>	
Perno antirotante interasse 110 mm <i>Stop-bar pin pitch 110 mm</i>	

### DOTAZIONE STANDARD STANDARD EQUIPMENT

Stop-block standard <i>Standard stop-block</i>	311201.025
Ghiera ER <i>ER nut</i>	
Chiave <i>Clamping wrench</i>	
Tubetto di grasso <i>Grease tube</i>	
Bauletto <i>Storage case</i>	

