



INO-System Spline Gauges and Special Designs - Almost everything is possible

*pure
perfection*

FRENCO

Indispensable for Constructional Feasibility!

“Go” and “not go” gauges are types of spline gauges.

Spline gauges provide a quick method of inspecting involute splines, serration splines and straight sided splines. “Go” gauges are still indispensable for inspecting constructional feasibility. “Not go” gauges, on the other hand, only represent a limited means of inspection.

Direct size inspection takes priority over “not go” gauges.

Plug gauges “go” – “not go”

Involute flanks



Serrated flanks



Straight flanks



Ring gauges “go” – “not go”

Involute flanks

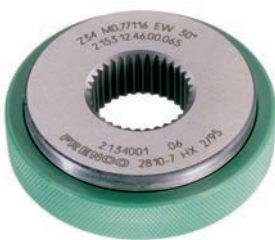

Serrated flanks



Straight flanks



Technical Standard

Spline gauges are described in several German and foreign standards as well as in the international standard ISO 4156. All these standards differ from one another and are neither comprehensive nor technically up-to-date. FRENCO's specialist knowledge facilitates more advanced diagnosis than in the currently applicable standards.

At the same time, FRENCO is working towards adapting the existing standards in the relevant committees. Spline gauges are usually ordered according to standards or by part number.

When comparing prices, references to the relevant standards are inadequate, as they do not satisfy the exacting demands of ISO 9000ff. These are defined below as characteristics, such that they may also be applied by certified companies.

• Gauge Drawings

- + Gauge drawings also contain a worn dimension for "not go" gauges
- + "Not go" gauge plugs have a complete pilot diameter
- + Ring gauges should be provided with protection against hand warmth
- + Modification statuses are noted on gauge drawings with dates
- + Repeat orders are assigned to the modification statuses
- + The gauge drawing includes a measuring pin change factor (AF1=)
- + Gauge drawings include wear limits for individual form deviations

• Gauge Design

- + All spline gauges are clearly and permanently labeled with profile data, user identification number, manufacturer's drawing and drawing number, material, serial number and date of manufacture.
- + Special steels are available for prolonged durability, reduction of test equipment monitoring costs or reduced manufacturing or wear tolerances. These have a higher alloy content and hardness.
- + Spline gauges are reusable. Worn gauges will be accepted against a charge.
- + Special delivery times down to a few days are possible in the case of urgent requirements.
- + "Go" gauges are green for pitch circles up to 50 mm, "not go" gauges are marked red.

• Quality

- + All spline gauges are supplied with a full calibrated certificate, including graphs of all individual form deviations. They comply with the requirements of ISO 9000ff and thus completely replace the incoming goods inspection. Exceptions are possible upon request.
- + Agreement B applies as the acceptance condition for maintaining the tolerance limits with prioritization according to OFD 11, page 17.
- + Directions are available for wear inspection at the user's premises.
- + War inspection of spline gauges is offered as a service

• Complaints

- + In the case of complaints, the user's testing costs arising will be reimbursed up to the test certificate price limit.
- + Claims for damages are possible if a calibration certificate was ordered.
- + Any remanufacture or rework will take place within shortest possible time.
- + A 5-year guarantee against material faults is provided. Should a material fault be ascertained within this period, reworking will take place at no charge.

The Frenco INO System

The INO system is a FRENCO internal standard for the external dimensional measurement of spline gauges. National and international standards were taken into consideration in its development and it represents an average of the dimensions specified in these standards. The construction considers the recyclability and manufacturability of the extremely wear-resistant material SX.

The tabulated dimensions for Frenco INO apply for all splines with involute and serration flanks.

Frenco INO-L is used as standard for "go" straight flank gauges.

INO-L dimensions are available for oversize gauges on request.

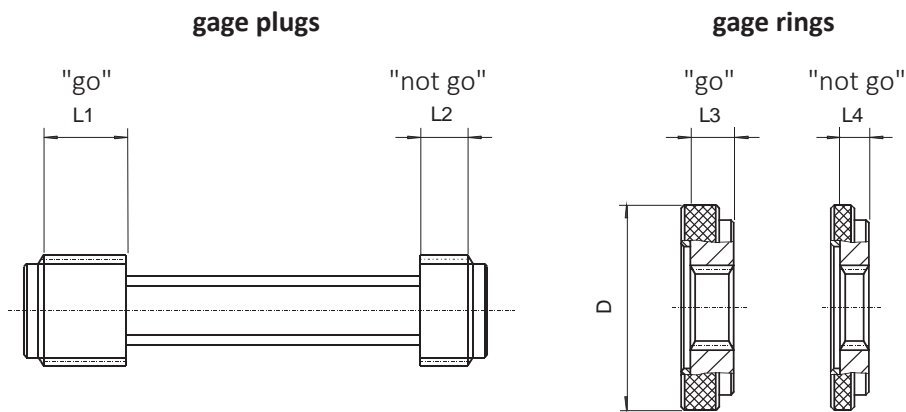

from $D \geq 125$ without plastic cap, L = total length

pure
perfection

FRENCO

Dimension	Pitch circle	D	FRENCO INO				FRENCO INO-L			
			L1	L2	L3	L4	L1	L2	L3	L4
4	7-12	53	8	6	12	9	12	8	16	12
6	>12-20	53	12	8	12	9	16	12	16	12
8	>20-25	70	15	10	16	11	20	15	20	16
10	>25-35	70	20	10	16	11	30	20	20	16
13	>35-45	100	25	15	20	15	40	25	25	20
16	>45-60	100	30	18	20	15	45	30	25	20
22	>60-80	125	30	18	25	15	50	30	30	25
32-1	>80-100	150	40	20	25	15	50	30	30	25
32-2	>100-130	175	40	20	30	20	55	40	40	30
45-1	>130-170	225	45	25	40	25	60	45	50	40
45-2	>170-(220)	275	50	30	40	30	70	50	50	40
45-3	>220-(290)	350	55	35	40	30	80	55	50	40

Selection of Materials

The content of chromium and vanadium alloy, as well as the hardness of the material, determine the wear resistance of the spline gauge. The time intervals between wear inspections depend on wear resistance, which means that highly wear resistant materials allow the monitoring periods to be significantly extended; this often more than compensates for the higher manufacturing costs.

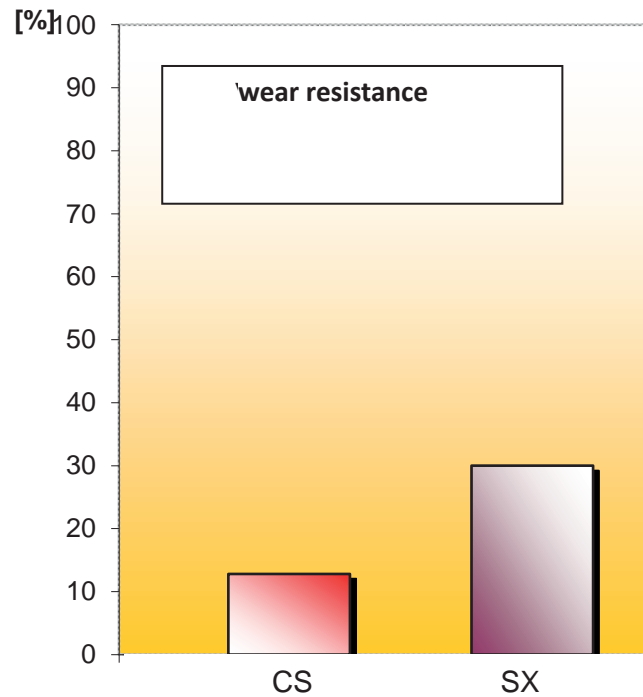

Material	Art	% C	% V	% Cr	HRc
CS	Chrome steel	1,5	0,85	12	60-62
SX	low alloy powder steel ASP 23	1,4	4	4	63-65

Delivery

Delivery capacity is restricted as a consequence of the technical niche position and the resulting limited availability of trained staff and technical equipment. Delivery times are therefore subject to fluctuations depending on demand and can only be arranged on a waiting list basis.

Gauge Drawings

The quoted prices for spline gauges always include the generation of comprehensive gauge drawings (also available in electronic form), as well as a full test certificate of the new condition from the FRENCO calibration laboratory.

DIN 5480 – N 23 x 1,75 x 12 x 30 x 9H LQ4		
Spline plug gauge	"Go" plug gauge	"Not go" plug gauge
Number of teeth	12	2 + 2
Module	1,75	
Pressure angle	30°	
Pitch circle Ø	21,000	
Base circle Ø	18,1865	
Root circle Ø	18,9	
Form Ø	19,40	
Tip Ø	22,720 _{-0,033}	22,545 _{-0,033}
Measuring pin Ø	3,50 (AF1=2,6)	
Thooth thickness	2,7920 ^{+0,007}	2,8550 ± 0,0035
Dimension over 2 pins	26,5582 ^{+0,0098}	26,6466 ± 0,0049
Worn tooth thickness	2,7810	2,8480
Worn dimension over pins	26,5427	26,6368
Reference axis = axis of profile	new condition	wear limit
Total profile deviation	0,004	0,006
Runout deviation	0,006	0,009
Total pitch deviation	0,006	0,009
Total helix trace deviation	0,004	0,006

Inspection in New Condition

Characteristic	Measurement uncertainty	Measurement methods	Notes
Damage		Visual gear inspection	Damage or rust is not permissible
Identity		Visual inspection of labeling	The labeling must include profile data, standard designation, date of manufacture and manufacturer's mark
Tooth thickness of plug gauge	0,001 to 0,003	Auxiliary dimension over 2 pins Auxiliary dimension over 2 measuring balls with Abbe measurement methods each over 90° in front, middle, rear Measuring force less than 1.5 N Measuring pins must be rubbed	Roundness deviation of the measuring pins or measuring balls: max. 0.0003 Deviation of the measuring pins or measuring balls from the nominal dimension: max. 0.001 Nominal dimension correction with actual measuring pin dimension is necessary.
Additionally for tooth space of Ring gauge	0,001bis 0,003	Size between pins by the use of gauge blocks. (see OFE 09) With master plug gauge – see OFR 12.	The gauge blocks having the actual dimension must not show any tilt clearance between both measuring pins; it must however still be axially slidable without sticking.
Tip Root circle \emptyset	0,002	Abbe measurement methods gear inspection machines	The root circle \emptyset is not checked along with flank centering.
Form circle \emptyset	0,010	Analytical inspection machines gear inspection machines	Check via roll distance or roll angle
Individual form deviations	0,002	Analytical inspection machines gear inspection machines Profile and lead at 4 right and left flanks Only for "go" gauges: Index of all tooth flanks	Reference axis pitch circle axis or with alignment diameter (lower priority) The measurement uncertainty of 0.002 is theoretically too large, but practically not better attainable.

As a result of the unfavorable relationship between gauge tolerances and the smallest attainable measuring uncertainty, spine gauges can only be rejected if the measured dimension lies outside the tolerance limits extended by the measurement uncertainty. (non-conformance zone according to DIN EN ISO 14253-1).

In the absence of explicit references to other regulations or agreements, agreement B applies with designation of priority according to the Frenco definition OFD 10, page 18.

Periodical Wear Inspection is necessary

Spline gauges are subject to wear during their use. A wear tolerance with a permissible wear limit for the worn dimension is designated for this purpose. Once the wear limit has been reached, these gauges are to be selected out. In many instances the wear is not uniformly distributed.

Testing of the individual form deviations at prescribed time intervals is therefore necessary (also see OFE 05 'Wear limit of "not go" spline gauges'). The table below gives reference values for the test cycles of the necessary monitoring of spline gauges.

These values are only rough estimates, as wear produces different effects in every case. The anticipated life-span, expressed in the number of parts inspections to be performed, serves as the basis for the monitoring cycle. After 25% of the total estimated life-span there should be a size inspection over or between pins; after 50% an inspection of dimensions and individual form deviation.

Gauge material		Number of material inspections	
		hardened	unhardened
chrome steel HRc 60-62 (CS)	estimated life-span	8 000	12 000
	size inspections per piece	2 000	3 000
	size and form inspections per piece	4 000	6 000
Low alloy powder HSS HRc 63-65 (SX)	estimated life-span	18 000	26 000
	size inspections per piece	4 500	6 500
	size and form inspections per piece	9 000	13 000

The estimated life-span of a gauge should be adjusted from experience according to the actual conditions. If the number of parts inspections is so low that a wear inspection of gauges is only required after a year, it is recommended to assign a period of a year for the size inspection and two years for the size and form inspection.

If in doubt, a size and form inspection should always be carried out for critical parts and for safety-relevant components.

For additional tolerances of single deviations from the tolerances in new condition – see the next but one page.

Wear Inspection of Spline Gauges

Characteristic	Measurement uncertainty	Measurement methods	Notes
Damage		Visual inspection of the gear and spline	small damage may be removed with a grinding stone
Identity		Visual inspection of labeling	The labeling must include profile data, standard designation and identification number
Tooth thickness of plug gauges	0,001 bis 0,003	Auxiliary dimension over 2 pins Auxiliary dimension over 2 measuring balls with Abbe measurement methods each over 90° in front, middle, rear measurement force < 1.5 N Measuring pins must be rubbed	Roundness deviation of the measuring pins or measuring balls: max. 0.0003 Deviation of measuring pins or measuring balls from the nominal size: max. 0.001 Nominal size correction with the actual size of the measuring pins or measuring balls is required.
Additionally for space width of ring gauges	0,001 bis 0,003	Size between between pins by the use of gauge blocks.	The gauge blocks with the actual dimension must not have any tilt clearance between both measuring pins; it must however still be axially slidable without sticking.
If the actual size of the tooth thickness / tooth space is exactly the same as the worn size, the inspection should be discontinued and the gauge no longer used.			
Tip \varnothing	0,002	Abbe measurement methods gear inspection machines	Abbe measuring methods are not possible for odd numbers of teeth
Form circle \varnothing	0,010	Analytical inspection machines gear inspection machines	Check via roll distance or roll angle
Individual form deviations	0,002	Analytical inspection machines gear inspection machines Profile and lead at 4 right and left flanks Only for "go" gauges: index of all tooth flanks	The measurement uncertainty of 0.002 is theoretically too large, but practically not better attainable. The individual deviations may exceed those of new gauges by the amounts overleaf.

As a result of the unfavorable relationship between gauge tolerances and the smallest attainable measuring uncertainty, spline gauges can only be rejected if the measured size lies outside the tolerance limits extended by the measurement uncertainty (non-conformance zone according to DIN EN ISO 14253-1).

In the absence of explicit references to other regulations or agreements, agreement B applies with priority regulation according to the Frenco definition OFD 10, page 18.

Tolerances

The individual deviations of spline gauges rise during wear if the wear is not uniformly distributed over all tooth flanks. If gauges have not yet reached the worn size, but the individual deviations exceed the additional tolerances with reference to the values in the new condition, these gauges are to be considered as worn and must be replaced.

Permissible assumed individual deviations of spline gauges during wear up to the worn dimension over/between pins (values of a similar order of magnitude are also included in the latest editions of DIN 5480 and ISO 4156):

Deviation		Tolerance in addition to the new tolerances	
		D = 0-50	50<D<300
Total profile deviation	F_{α}	+ 0,002	+ 0,003
Total lead deviation	F_{β}	+ 0,001	+ 0,002
Runout deviation	F_R	+ 0,002	+ 0,003
Total pitch deviation	F_p	+ 0,002	+ 0,003
Individual pitch deviation	f_p	+ 0,001	+ 0,002

VZ-Cap

Advantages:

- ✓ faster finding of position for go ring gauge
- ✓ safe correct decision
- ✓ more stress-free work
- ✓ old version can be replaced

Patent number
EP 3 550 255 B1

Pilot diameter cap for easier gauge inspection

Specials

Special gauges are custom manufactured according to drawings. Here there are almost no limitations.

Special ring gauge



Master plug gauges for spline gauge rings



Setting master





Pure Perfection. Since 1978.

Experience, competence and innovation in gear metrology.



Our Products:

Spline Gauges | Toothed Artefacts and Masters | Master Gears |
Tools and Clamping Systems | Size Inspection Instruments |
Double Flank Gear Inspection | Gear Flank Analyser | Universal
Measuring Machines | Rack Inspection Machines | Software

Our Services:

DAKKS Calibration | Gear and Spline Inspection |
Gear and Spline Manufacturing | Seminars | Service |
Support and Calculation

Phone: +49 (0) 9187 95 22 0

FRESCO GmbH

Gear + Spline Technology

Jakob-Baier-Str. 3 • D - 90518 Altdorf

www.fresco.com



FRESCO