



TESTE ANGOLARI MULTI-WAY MULTI-WAY ANGLE HEADS

FORATURA
DRILLING



MASCHIATURA
TAPPING



SPECIFICHE TECNICHE TECHNICAL FEATURES

Modello <i>Type</i>	A25/20-SK40	Codice <i>Code</i>	128909.100
Modello <i>Type</i>	A25/20-BT40	Codice <i>Code</i>	128910.100
Modello <i>Type</i>	A25/20-CAT40	Codice <i>Code</i>	128913.100
Modello <i>Type</i>	A25/20-HSK63	Codice <i>Code</i>	128914.100
Mandrino porta-utensile per pinza <i>Tool-holder for collet</i>	ER 25/ER 20		
Rotazione cono <i>Input shank rotation</i>	DX / LH		
Rotazione mandrino <i>Output spindle rotation</i>	DX / RH		
Rapporto di trasmissione <i>Transmission ratio</i>	1:1		
Velocità max <i>Max speed</i>	5000 rpm		
Coppia <i>Torque</i>	19 Nm		
Lubrificazione a grasso <i>Grease lubricated</i>	Klüber Isoflex NBU 15		

OPZIONI OPTIONS

Pinza ER20 DIN 6499/B <i>ER20 collet DIN 6499/B</i>	411220.100
Pinza di maschiatura ET-1-20 con compensazione <i>Tapping collet ET-1-20 with compensation</i>	401220.200
Pinza di maschiatura ER20 con quadro <i>Tapping collet ER20 with square</i>	411220.200
Pinza ER25 DIN 6499/B <i>ER25 collet DIN 6499/B</i>	411225.100
Pinza di maschiatura ET-1-25 con compensazione <i>Tapping collet ET-1-25 with compensation</i>	401225.200
Pinza di maschiatura ER25 con quadro <i>Tapping collet ER25 with square</i>	411225.200
Mandrino Weldon <i>Weldon spindle type</i>	
Mandrino ABS licenza Komet® <i>ABS license Komet® spindle type</i>	
Mandrino DIN 69893-HSK <i>DIN 69893-HSK spindle type</i>	

DOTAZIONE STANDARD STANDARD EQUIPMENT

Stop-block standard <i>Standard stop-block</i>	311201.025
Ghiera ER <i>ER nut</i>	
Chiave <i>Clamping wrench</i>	
Tubetto di grasso <i>Grease tube</i>	
Bauletto <i>Storage case</i>	

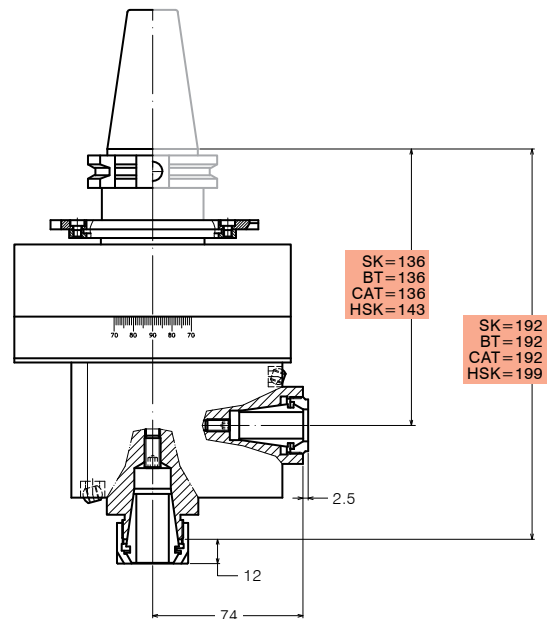
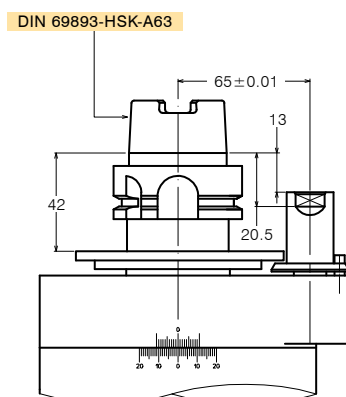
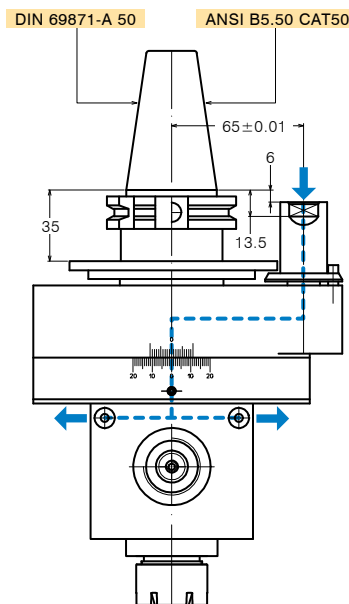
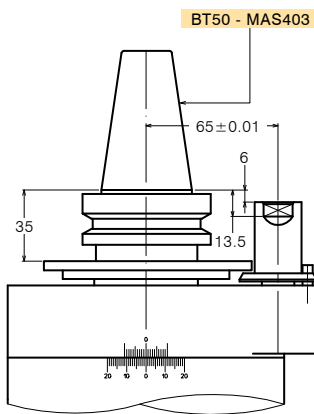
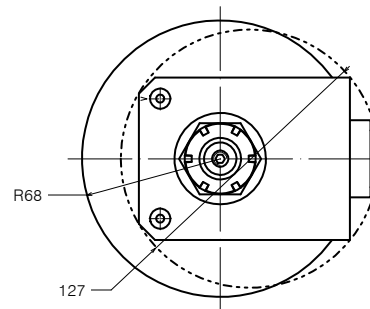



TESTE ANGOLARI MULTI-WAY MULTI-WAY ANGLE HEADS

FORATURA
DRILLING



MASCHIATURA
TAPPING



SPECIFICHE TECNICHE TECHNICAL FEATURES

Modello <i>Type</i>	A32/25-25-SK50	Codice <i>Code</i>	128903.100
Modello <i>Type</i>	A32/25-25-BT50	Codice <i>Code</i>	128904.100
Modello <i>Type</i>	A32/25-25-CAT50	Codice <i>Code</i>	128907.100
Modello <i>Type</i>	A32/25-25-HSK100	Codice <i>Code</i>	128908.100
Mandrino porta-utensile per pinza <i>Tool-holder for collet</i>	ER 32/ER 25 - ER 25		
Rotazione cono <i>Input shank rotation</i>	DX / LH		
Rotazione mandrino <i>Output spindle rotation</i>	DX / RH		
Rapporto di trasmissione <i>Transmission ratio</i>	1:1		
Velocità max <i>Max speed</i>	4000 rpm		
Coppia <i>Torque</i>	31 Nm		
Peso <i>Weight</i>	15.6 Kg		
Lubrificazione a grasso <i>Grease lubricated</i>	Klüber Isoflex NBU 15		

OPZIONI OPTIONS

Pinza ER25 DIN 6499/B <i>ER25 collet DIN 6499/B</i>	411225.100
Pinza di maschiatura ET-1-25 con compensazione <i>Tapping collet ET-1-25 with compensation</i>	401225.200
Pinza di maschiatura ER25 con quadro <i>Tapping collet ER25 with square</i>	411225.200
Pinza ER32 DIN 6499/B <i>ER32 collet DIN 6499/B</i>	411232.100
Pinza di maschiatura ET-1-32 con compensazione <i>Tapping collet ET-1-32 with compensation</i>	401232.200
Pinza di maschiatura ER32 con quadro <i>Tapping collet ER32 with square</i>	411232.200
Mandrino Weldon <i>Weldon spindle type</i>	
Mandrino ABS licenza Komet® <i>ABS license Komet® spindle type</i>	
Mandrino DIN 69893-HSK <i>DIN 69893-HSK spindle type</i>	

DOTAZIONE STANDARD STANDARD EQUIPMENT

Stop-block standard <i>Standard stop-block</i>	311201.025
Ghiera ER <i>ER nut</i>	
Chiave <i>Clamping wrench</i>	
Tubetto di grasso <i>Grease tube</i>	
Bauletto <i>Storage case</i>	

