



TESTE ANGOLARI PER LAVORAZIONI PESANTI ANGLE HEADS FOR HEAVY DUTY

FORATURA
DRILLING



MASCHIATURA
TAPPING



SPECIFICHE TECNICHE TECHNICAL FEATURES

Modello <i>Type</i>	A-ISO30-SK40	Codice <i>Code</i>	124705.100
Modello <i>Type</i>	A-ISO30-BT40	Codice <i>Code</i>	124706.100
Modello <i>Type</i>	A-ISO30-CAT40	Codice <i>Code</i>	124707.100
Modello <i>Type</i>	A-ISO30-HSK63	Codice <i>Code</i>	124708.100
Mandrino porta-utensile <i>Spindle tool-holder</i>	DIN 2079-30		
Rotazione cono <i>Input shank rotation</i>	SX / LH		
Rotazione mandrino <i>Output spindle rotation</i>	DX / RH		
Rapporto di trasmissione <i>Transmission ratio</i>	1:1		
Velocità max <i>Max speed</i>	3500 rpm		
Coppia <i>Torque</i>	40 Nm		
Carico assiale max <i>Max axial load</i>	750 N		
Peso <i>Weight</i>	7.4 Kg		
Lubrificazione a grasso <i>Grease lubricated</i>	Klüber Isoflex NBU 15		

OPZIONI OPTIONS

Mandrino Weldon *Weldon spindle type*
 Albero porta-fresa *Mill arbor*
 Perno antirotante interasse 80 mm
Stop-bar pin pitch 80 mm

DOTAZIONE STANDARD STANDARD EQUIPMENT

Stop-block standard *Standard stop-block* 311201.025
 Tubetto di grasso *Grease tube*
 Bauletto *Storage case*

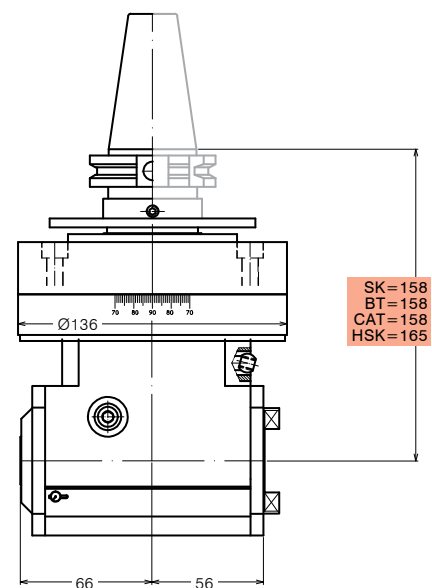
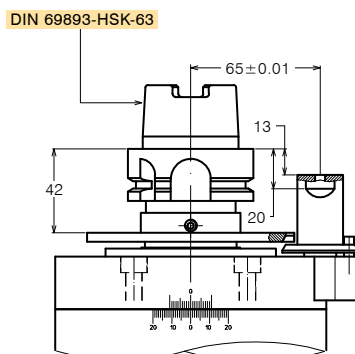
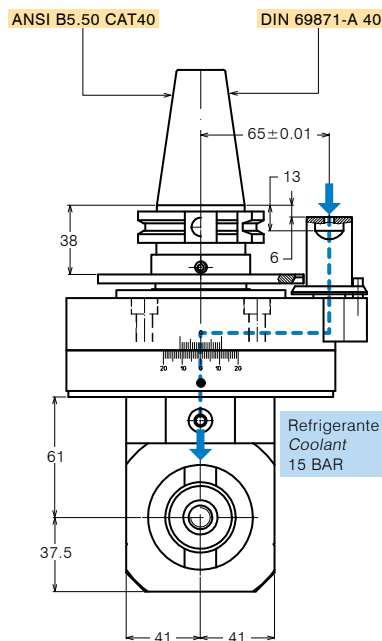
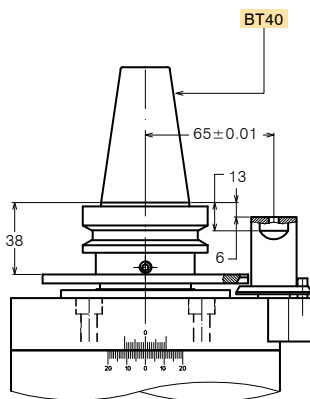
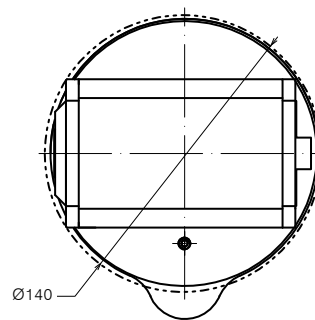



TESTE ANGOLARI PER LAVORAZIONI PESANTI ANGLE HEADS FOR HEAVY DUTY

FORATURA
DRILLING



MASCHIATURA
TAPPING



SPECIFICHE TECNICHE TECHNICAL FEATURES

Modello <i>Type</i>	A-ISO30-SK50	Codice <i>Code</i>	124710.100
Modello <i>Type</i>	A-ISO30-BT50	Codice <i>Code</i>	124709.100
Modello <i>Type</i>	A-ISO30-CAT50	Codice <i>Code</i>	124711.100
Modello <i>Type</i>	A-ISO30-HSK100	Codice <i>Code</i>	124712.100
Mandrino porta-utensile <i>Spindle tool-holder</i>	DIN 2079-30		
Rotazione cono <i>Input shank rotation</i>	SX / LH		
Rotazione mandrino <i>Output spindle rotation</i>	DX / RH		
Rapporto di trasmissione <i>Transmission ratio</i>	1:1		
Velocità max <i>Max speed</i>	4000 rpm		
Coppia <i>Torque</i>	40 Nm		
Carico assiale max <i>Max axial load</i>	750 N		
Peso <i>Weight</i>	11 Kg		
Lubrificazione a grasso <i>Grease lubricated</i>	Klüber Isoflex NBU 15		

OPZIONI OPTIONS

Mandrino Weldon *Weldon spindle type*
Albero porta-fresa *Mill arbor*

DOTAZIONE STANDARD STANDARD EQUIPMENT

Stop-block standard *Standard stop-block* 311201.026
Tubetto di grasso *Grease tube*
Bauletto *Storage case*

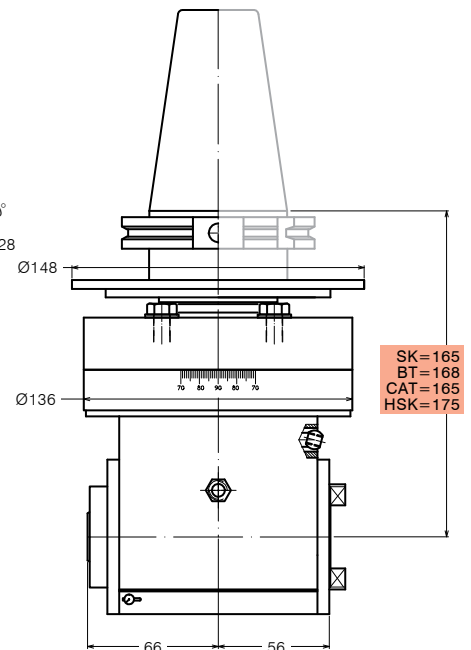
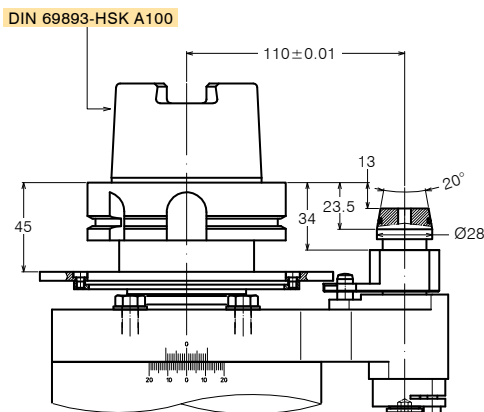
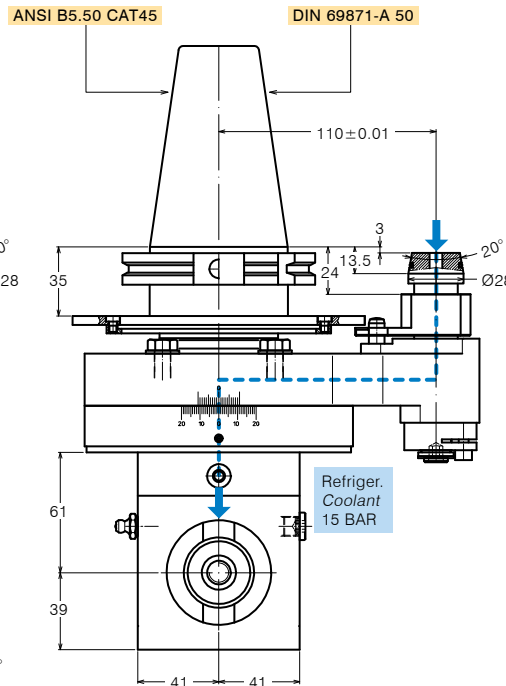
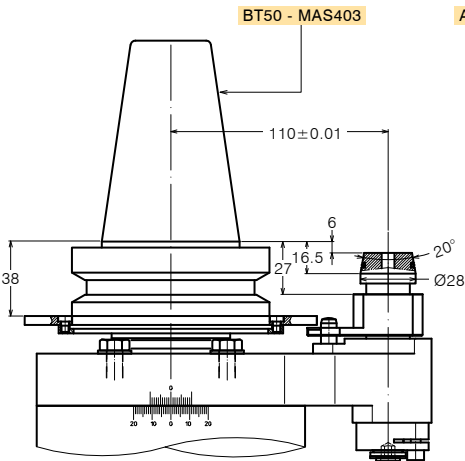
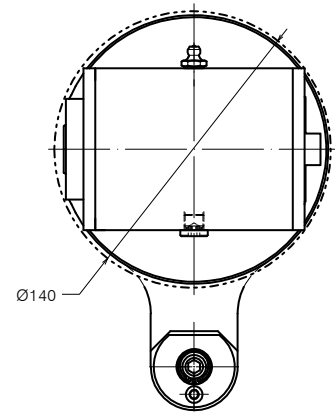



TESTE ANGOLARI PER LAVORAZIONI PESANTI ANGLE HEADS FOR HEAVY DUTY

FORATURA
DRILLING



MASCHIATURA
TAPPING



SPECIFICHE TECNICHE TECHNICAL FEATURES

Modello <i>Type</i>	A-ISO30-SK50-E240	Codice <i>Code</i>	124717.100
Modello <i>Type</i>	A-ISO30-BT50-E243	Codice <i>Code</i>	124718.100
Modello <i>Type</i>	A-ISO30-CAT50-E240	Codice <i>Code</i>	124719.100
Modello <i>Type</i>	A-ISO30-HSK100-E250	Codice <i>Code</i>	124720.100
Mandrino porta-utensile <i>Spindle tool-holder</i>	DIN 2079-30		
Rotazione cono <i>Input shank rotation</i>	DX / RH		
Rotazione mandrino <i>Output spindle rotation</i>	DX / RH		
Rapporto di trasmissione <i>Transmission ratio</i>	1:1		
Velocità max <i>Max speed</i>	4000 rpm		
Coppia <i>Torque</i>	100 Nm		
Peso <i>Weight</i>	24 Kg		
Lubrificazione a grasso <i>Grease lubricated</i>	Klüber Isoflex NBU 15		

OPZIONI OPTIONS

Mandrino Weldon *Weldon spindle type*
Albero porta-fresa *Mill arbor*

DOTAZIONE STANDARD STANDARD EQUIPMENT

Stop-block standard *Standard stop-block* 311201.026
Tubetto di grasso *Grease tube*
Bauletto *Storage case*

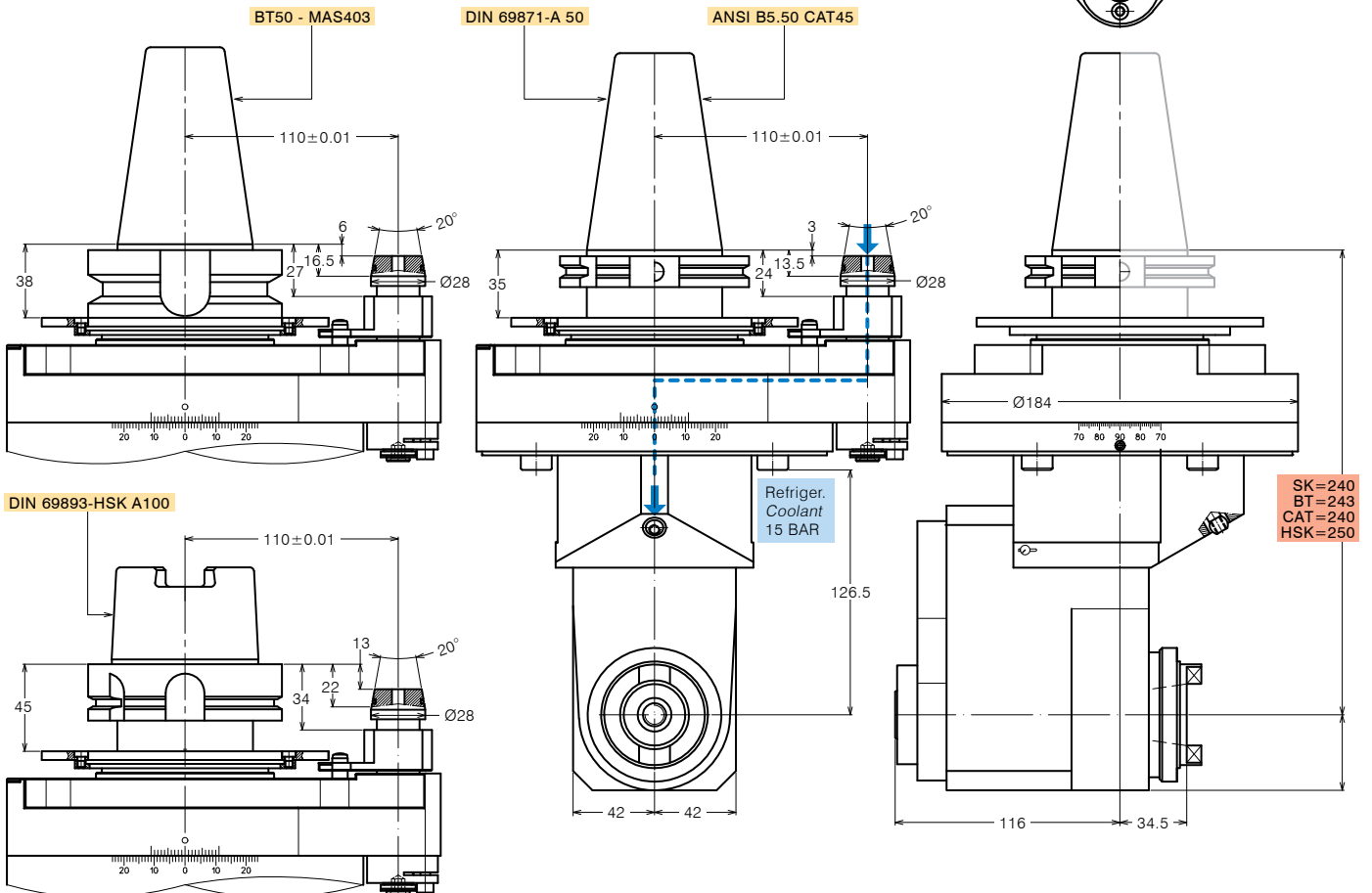
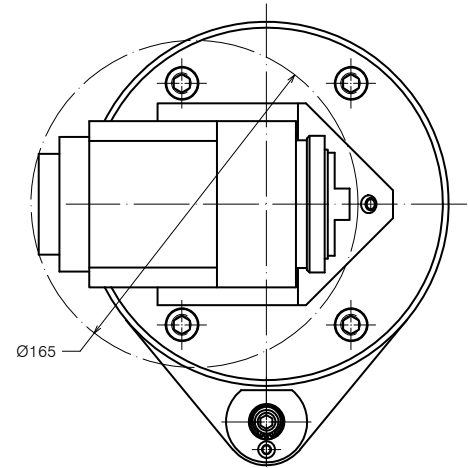



TESTE ANGOLARI PER LAVORAZIONI PESANTI ANGLE HEADS FOR HEAVY DUTY

FORATURA
DRILLING



MASCHIATURA
TAPPING



SPECIFICHE TECNICHE TECHNICAL FEATURES

Modello *Type* A-ISO40-SK50 Codice *Code* 124701.100

Modello *Type* A-ISO40-BT50 Codice *Code* 124702.100

Modello *Type* A-ISO40-CAT50 Codice *Code* 124703.100

Modello *Type* A-ISO40-HSK100 Codice *Code* 124704.100

Mandrino porta-utensile <i>Spindle tool-holder</i>	DIN 2079-40
Rotazione cono <i>Input shank rotation</i>	SX / LH
Rotazione mandrino <i>Output spindle rotation</i>	DX / RH
Rapporto di trasmissione <i>Transmission ratio</i>	1:1
Velocità max <i>Max speed</i>	4000 rpm
Coppia <i>Torque</i>	110 Nm
Carico assiale max <i>Max axial load</i>	1250 N
Peso <i>Weight</i>	22.5 Kg
Lubrificazione a grasso <i>Grease lubricated</i>	Klüber Isoflex NBU 15

OPZIONI OPTIONS

Mandrino Weldon *Weldon spindle type*

Albero porta-fresa *Mill arbor*

DOTAZIONE STANDARD STANDARD EQUIPMENT

Stop-block standard *Standard stop-block* 311201.026

Tubetto di grasso *Grease tube*

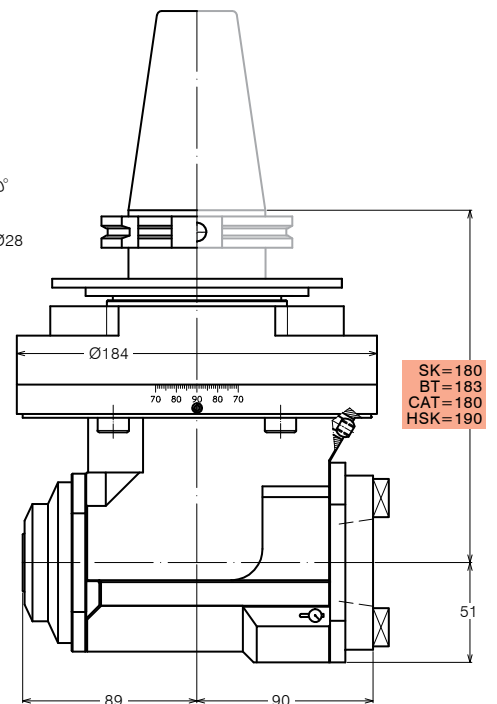
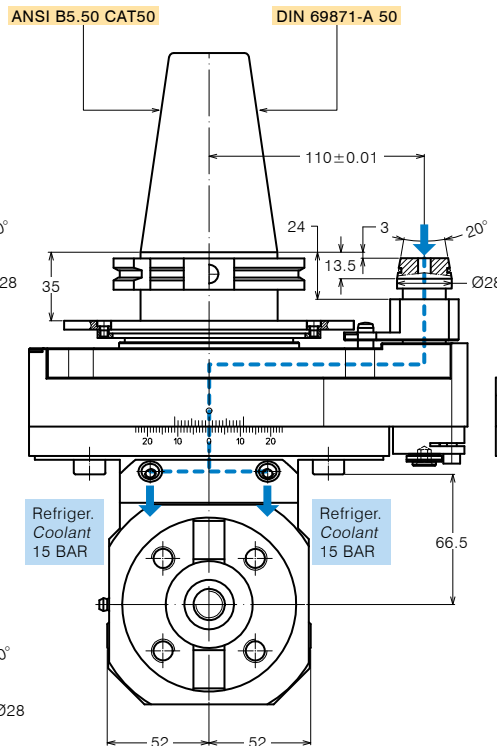
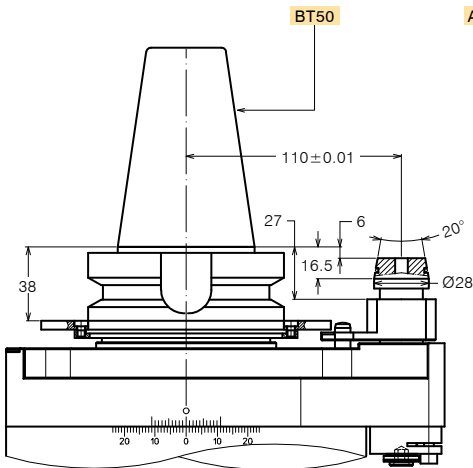
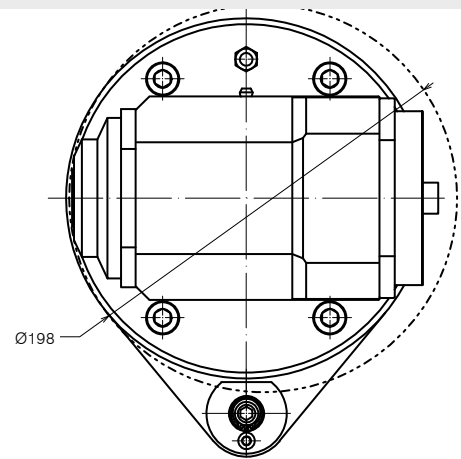

DIN 69893-HSK A100

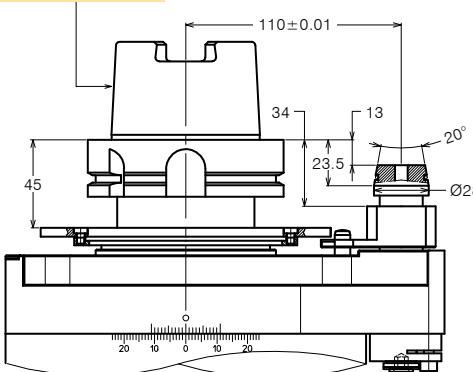



TESTE ANGOLARI PER LAVORAZIONI PESANTI ANGLE HEADS FOR HEAVY DUTY

FORATURA
DRILLING



MASCHIATURA
TAPPING



SPECIFICHE TECNICHE TECHNICAL FEATURES

Modello <i>Type</i>	A-ISO40-SK50-E250	Codice <i>Code</i>	124713.100
Modello <i>Type</i>	A-ISO40-BT50-E253	Codice <i>Code</i>	124714.100
Modello <i>Type</i>	A-ISO40-CAT50-E250	Codice <i>Code</i>	124715.100
Modello <i>Type</i>	A-ISO40-HSK100-E260	Codice <i>Code</i>	124716.100
Mandrino porta-utensile <i>Spindle tool-holder</i>	DIN 2079-40		
Rotazione cono <i>Input shank rotation</i>	SX / LH		
Rotazione mandrino <i>Output spindle rotation</i>	DX / RH		
Rapporto di trasmissione <i>Transmission ratio</i>	1:1		
Velocità max <i>Max speed</i>	3000 rpm		
Coppia <i>Torque</i>	110 Nm		
Carico assiale max <i>Max axial load</i>	800 N		
Peso <i>Weight</i>	26.5 Kg		
Lubrificazione a grasso <i>Grease lubricated</i>	Klüber Isoflex NBU 15		

OPZIONI OPTIONS

Mandrino Weldon *Weldon spindle type*
 Albero porta-fresa *Mill arbor*

DOTAZIONE STANDARD STANDARD EQUIPMENT

Stop-block standard *Standard stop-block* 311201.026
 Tubetto di grasso *Grease tube*
 Bauletto *Storage case*

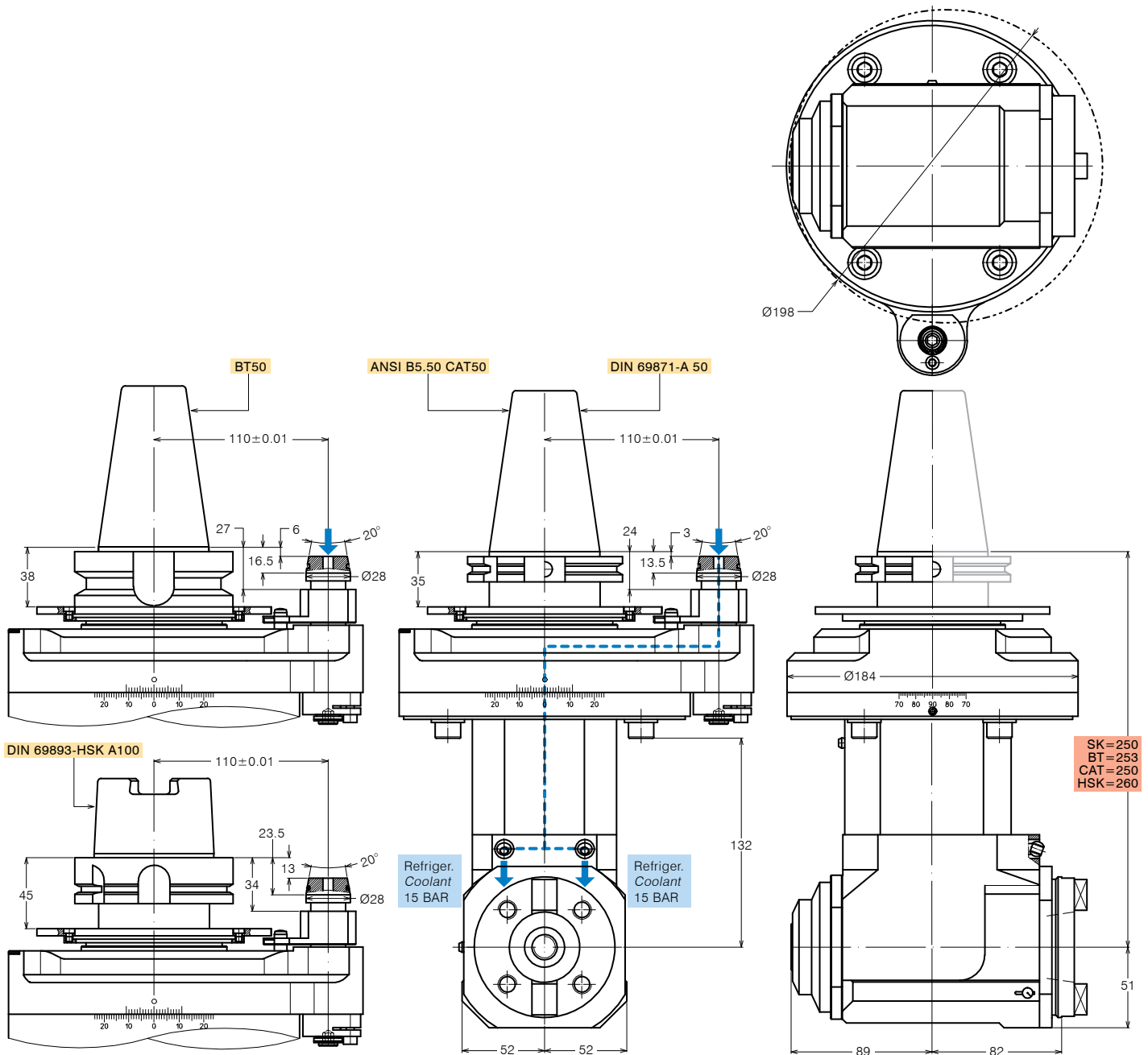



TESTE ANGOLARI PER LAVORAZIONI PESANTI ANGLE HEADS FOR HEAVY DUTY

FORATURA
DRILLING



MASCHIATURA
TAPPING



SPECIFICHE TECNICHE TECHNICAL FEATURES

Modello <i>Type</i>	A-HSK63-SK50	Codice <i>Code</i>	124601.100
Modello <i>Type</i>	A-HSK63-BT50	Codice <i>Code</i>	124602.100
Modello <i>Type</i>	A-HSK63-CAT50	Codice <i>Code</i>	124603.100
Modello <i>Type</i>	A-HSK63-HSK100	Codice <i>Code</i>	124604.100
Mandrino porta-utensile <i>Spindle tool-holder</i>	DIN69893 HSK63		
Rotazione cono <i>Input shank rotation</i>	SX / LH		
Rotazione mandrino <i>Output spindle rotation</i>	DX / RH		
Rapporto di trasmissione <i>Transmission ratio</i>	1:1		
Velocità max <i>Max speed</i>	3000 rpm		
Coppia <i>Torque</i>	110 Nm		
Carico assiale max <i>Max axial load</i>	1250 N		
Peso <i>Weight</i>	22.5 Kg		
Lubrificazione a grasso <i>Grease lubricated</i>	Klüber Isoflex NBU 15		

OPZIONI OPTIONS

Mandrino Weldon *Weldon spindle type*

DOTAZIONE STANDARD STANDARD EQUIPMENT

Stop-block standard <i>Standard stop-block</i>	311201.026
Tubetto di grasso <i>Grease tube</i>	
Bauletto <i>Storage case</i>	

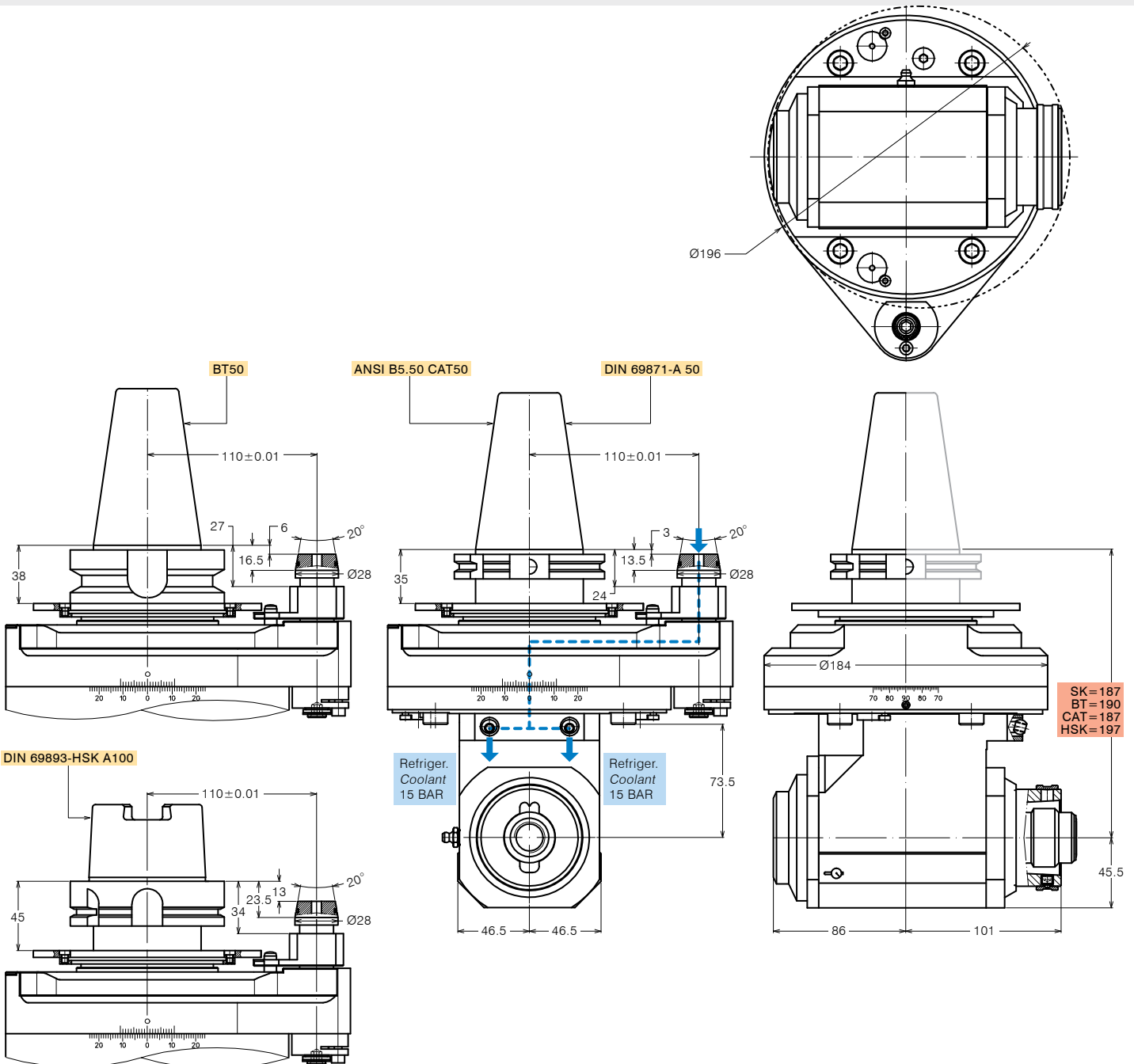



TESTE ANGOLARI PER LAVORAZIONI PESANTI ANGLE HEADS FOR HEAVY DUTY

FORATURA
DRILLING



MASCHIATURA
TAPPING



REFRIGERANTE
COOLANT



SPECIFICHE TECNICHE TECHNICAL FEATURES

Modello *Type* A-HSK63R-SK50R Codice *Code* 124613.100

Modello *Type* A-HSK63R-BT50R Codice *Code* 124614.100

Modello *Type* A-HSK63R-CAT50R Codice *Code* 124615.100

Modello *Type* A-HSK63R-HSK100R Codice *Code* 124616.100

Mandrino porta-utensile <i>Spindle tool-holder</i>	DIN69893 HSK63
Rotazione cono <i>Input shank rotation</i>	SX / LH
Rotazione mandrino <i>Output spindle rotation</i>	DX / RH
Rapporto di trasmissione <i>Transmission ratio</i>	1:1
Velocità max <i>Max speed</i>	3000 rpm
Coppia <i>Torque</i>	110 Nm
Carico assiale max <i>Max axial load</i>	1250 N
Peso <i>Weight</i>	22.5 Kg
Lubrificazione a grasso <i>Grease lubricated</i>	Klüber Isoflex NBU 15

OPZIONI OPTIONS

Mandrino Weldon *Weldon spindle type*

DOTAZIONE STANDARD STANDARD EQUIPMENT

Stop-block standard *Standard stop-block* 311201.026

Tubetto di grasso *Grease tube*

Bauletto *Storage case*

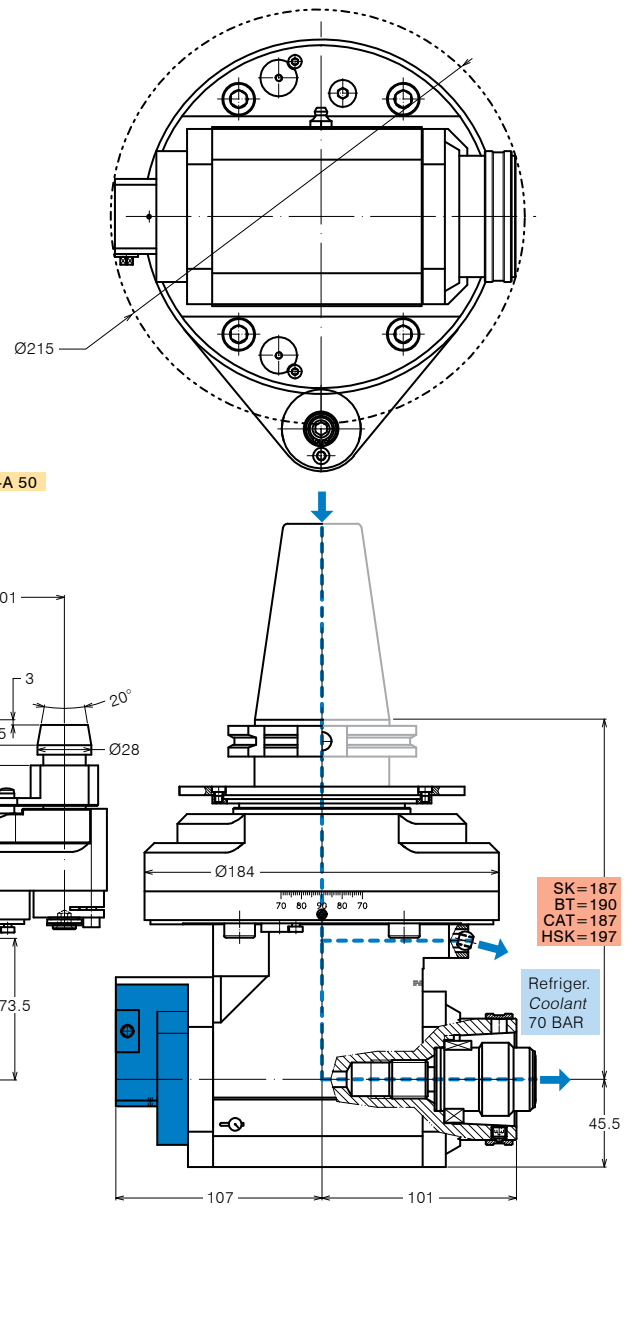



TESTE ANGOLARI PER LAVORAZIONI PESANTI ANGLE HEADS FOR HEAVY DUTY

FRESATURA
MILLING



SPECIFICHE TECNICHE TECHNICAL FEATURES

Modello *Type* A032-BT50 Codice *Code* A242874.101

Albero porta-fresa <i>Mill arbor</i>	Ø32
Rotazione cono <i>Input shank rotation</i>	SX / LH
Rotazione mandrino <i>Output spindle rotation</i>	DX / RH
Rapporto di trasmissione <i>Transmission ratio</i>	1:1
Velocità max <i>Max speed</i>	3000 rpm
Coppia <i>Torque</i>	110 Nm
Carico assiale max <i>Max axial load</i>	1250 N
Peso <i>Weight</i>	22 Kg
Lubrificazione a grasso <i>Grease lubricated</i>	Klüber Isoflex NBU 15

DOTAZIONE STANDARD STANDARD EQUIPMENT

Stop-block standard *Standard stop-block* 311201.026
Bauletto *Storage case*

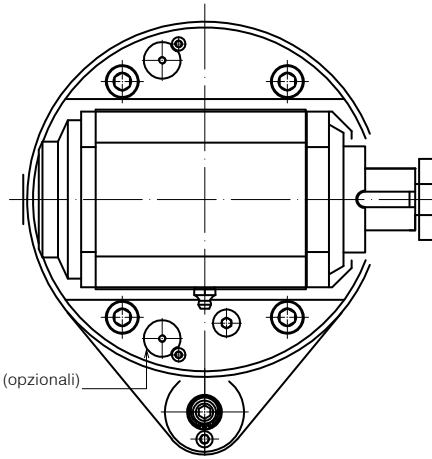

Riferimenti per base di supporto (opzionali)
Craddle references (optional)

