



TESTE ANGOLARI SLIM SLIM ANGLE HEADS

FORATURA
DRILLING



SPECIFICHE TECNICHE TECHNICAL FEATURES

Modello *Type* A5-SK40-S221 Codice *Code* 124401.100-S221

Modello *Type* A5-BT40-S227 Codice *Code* 124402.100-S227

Modello *Type* A5-CAT40-S221 Codice *Code* 124403.100-S221

Modello *Type* A5-HSK63-S228 Codice *Code* 124404.100-S228

Mandrino porta-utensile per pinza *Tool-holder for collet* **6023E**
 Rotazione cono *Input shank rotation* SX / LH
 Rotazione mandrino *Output spindle rotation* DX / RH
 Rapporto di trasmissione *Transmission ratio* 1:1
 Velocità max *Max speed* 7000 rpm
 Coppia *Torque* 1 Nm
 Peso *Weight* 5 Kg
 Lubrificazione a grasso *Grease lubricated* Klüber Isoflex NBU 15

OPZIONI OPTIONS

Pinza 6023E *6023E collet*
 Perno antirotante interasse 80 mm
Pin pitch 80 mm

DOTAZIONE STANDARD STANDARD EQUIPMENT

Stop-block standard *Standard stop-block* 311201.025
 Tubetto di grasso *Grease tube*
 Bauletto *Storage case*

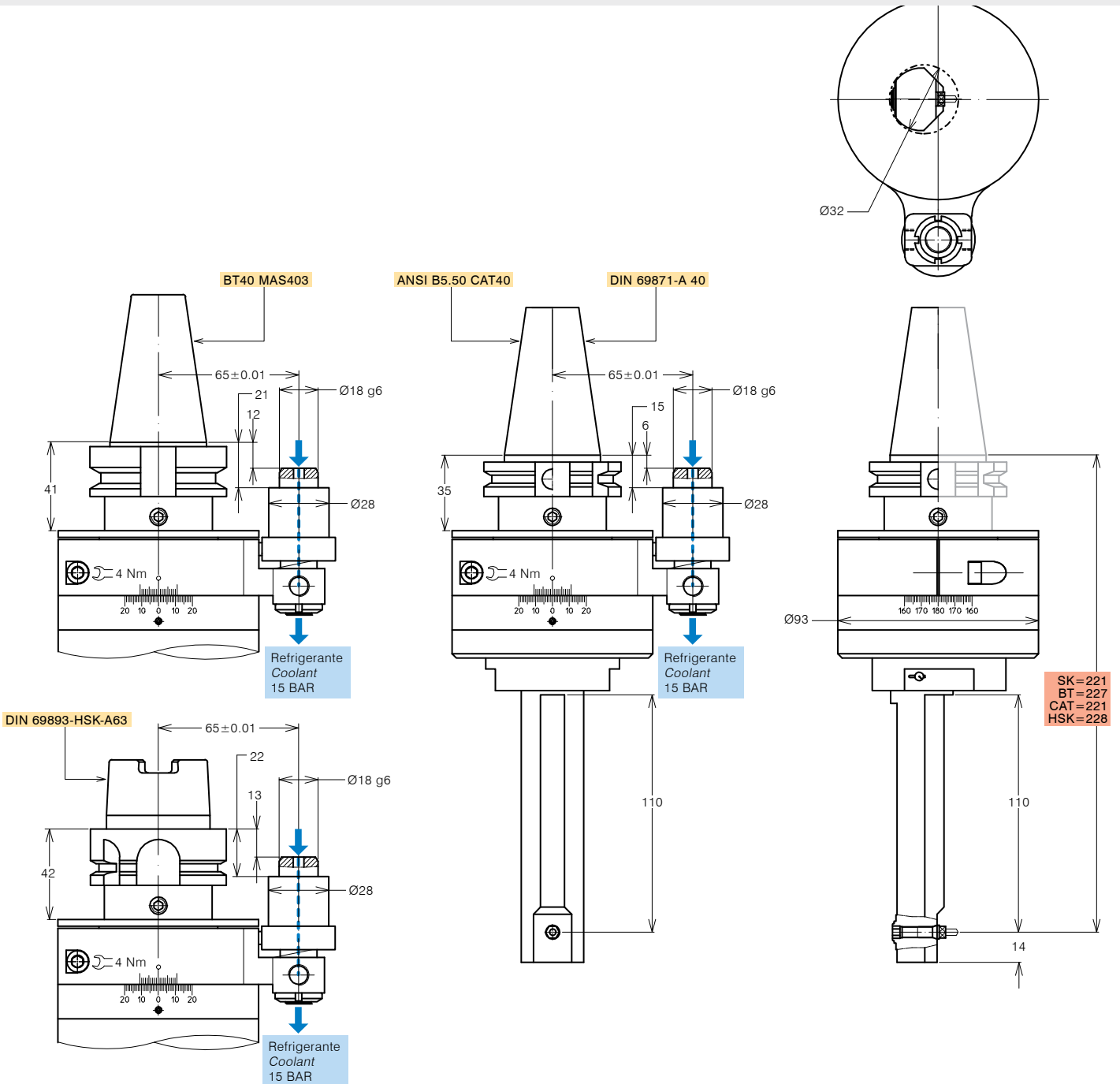

SPECIFICHE TECNICHE TECHNICAL FEATURES

 Modello *Type* A5-SK40-S218 Codice *Code* 124405.100-S218

 Modello *Type* A5-BT40-S223 Codice *Code* 124406.100-S223

 Modello *Type* A5-CAT40-S218 Codice *Code* 124407.100-S218

 Modello *Type* A5-HSK63-S225 Codice *Code* 124408.100-S225

Mandrino porta-utensile per pinza <i>Tool-holder for collet</i>	6023E
Rotazione cono <i>Input shank rotation</i>	DX / RH
Rotazione mandrino <i>Output spindle rotation</i>	DX / RH
Rapporto di trasmissione <i>Transmission ratio</i>	1:1.1
Velocità max <i>Max speed</i>	8000 rpm
Coppia <i>Torque</i>	4.5 Nm
Peso <i>Weight</i>	5 Kg
Lubrificazione a grasso <i>Grease lubricated</i>	Klüber Isoflex NBU 15

OPZIONI OPTIONS

 Pinza 6023E *6023E collet*
 Perno antirotante interasse 80 mm
Pin pitch 80 mm
DOTAZIONE STANDARD STANDARD EQUIPMENT

Stop-block standard <i>Standard stop-block</i>	311201.025
Tubetto di grasso <i>Grease tube</i>	
Bauletto <i>Storage case</i>	

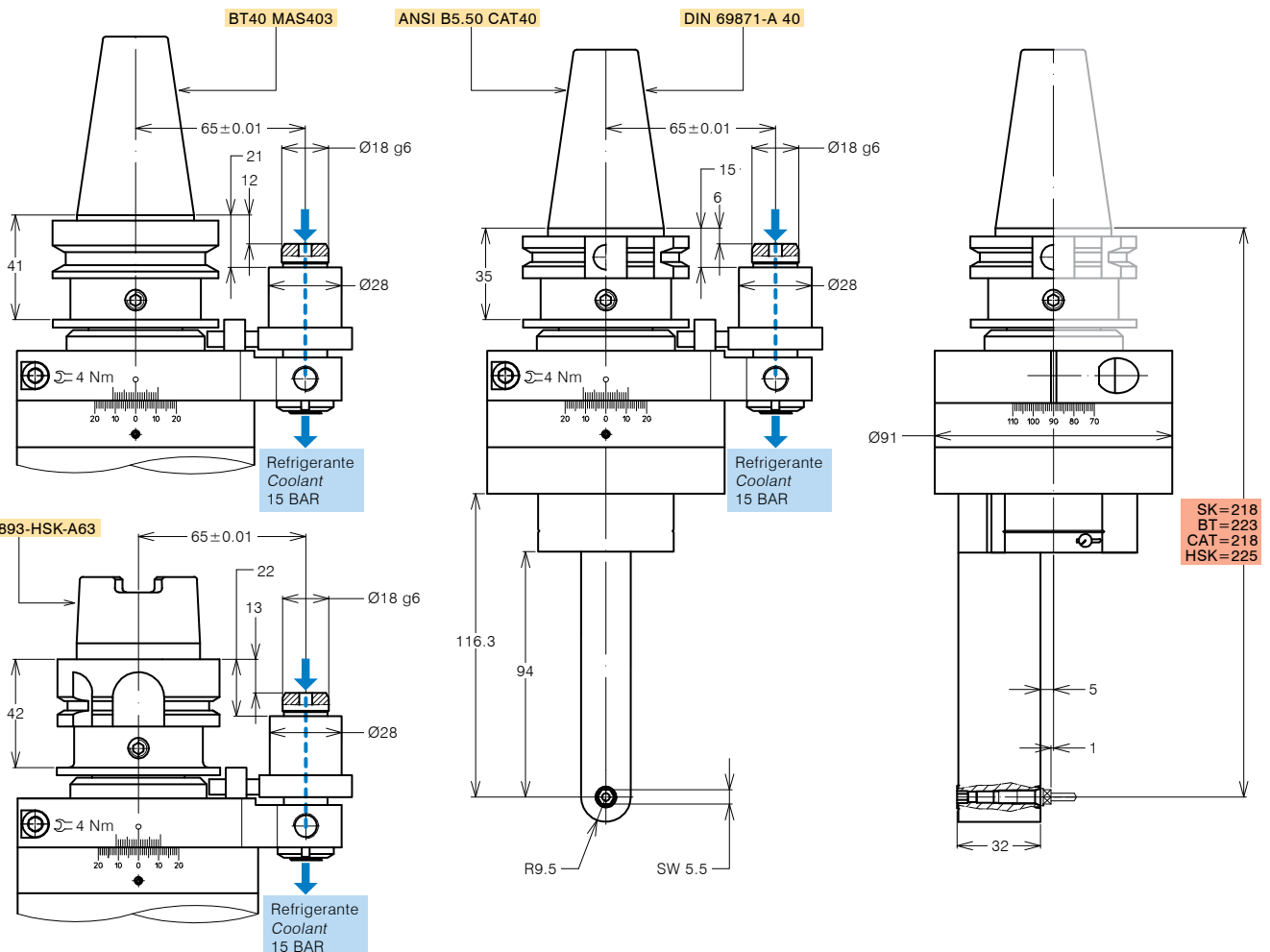
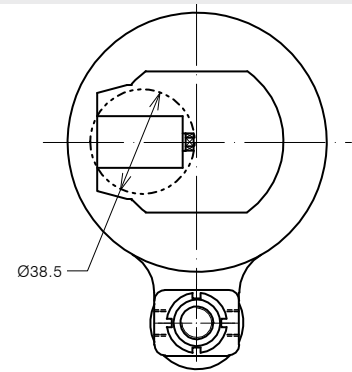



TESTE ANGOLARI SLIM SLIM ANGLE HEADS

FORATURA
DRILLING

Ø3

SPECIFICHE TECNICHE TECHNICAL FEATURES

Modello *Type* A5-SK50-S243 Codice *Code* 124409.100-S243

Modello *Type* A5-BT50-S257 Codice *Code* 124410.100-S257

Modello *Type* A5-CAT50-S243 Codice *Code* 124411.100-S243

Modello *Type* A5-HSK100-S253 Codice *Code* 124412.100-S253

Mandrino porta-utensile per pinza *Tool-holder for collet* **6023E**
 Rotazione cono *Input shank rotation* SX / LH
 Rotazione mandrino *Output spindle rotation* DX / RH
 Rapporto di trasmissione *Transmission ratio* 1:1.1
 Velocità max *Max speed* 8000 rpm
 Coppia *Torque* 4.5 Nm
 Peso *Weight* 10.5 Kg
 Lubrificazione a grasso *Grease lubricated* Klüber Isoflex NBU 15

OPZIONI OPTIONS

Pinza 6023E *6023E collet*
 Perno antirotante interasse 110 mm
Pin pitch 110 mm

DOTAZIONE STANDARD STANDARD EQUIPMENT

Stop-block standard *Standard stop-block* 311201.025
 Tubetto di grasso *Grease tube*
 Bauletto *Storage case*

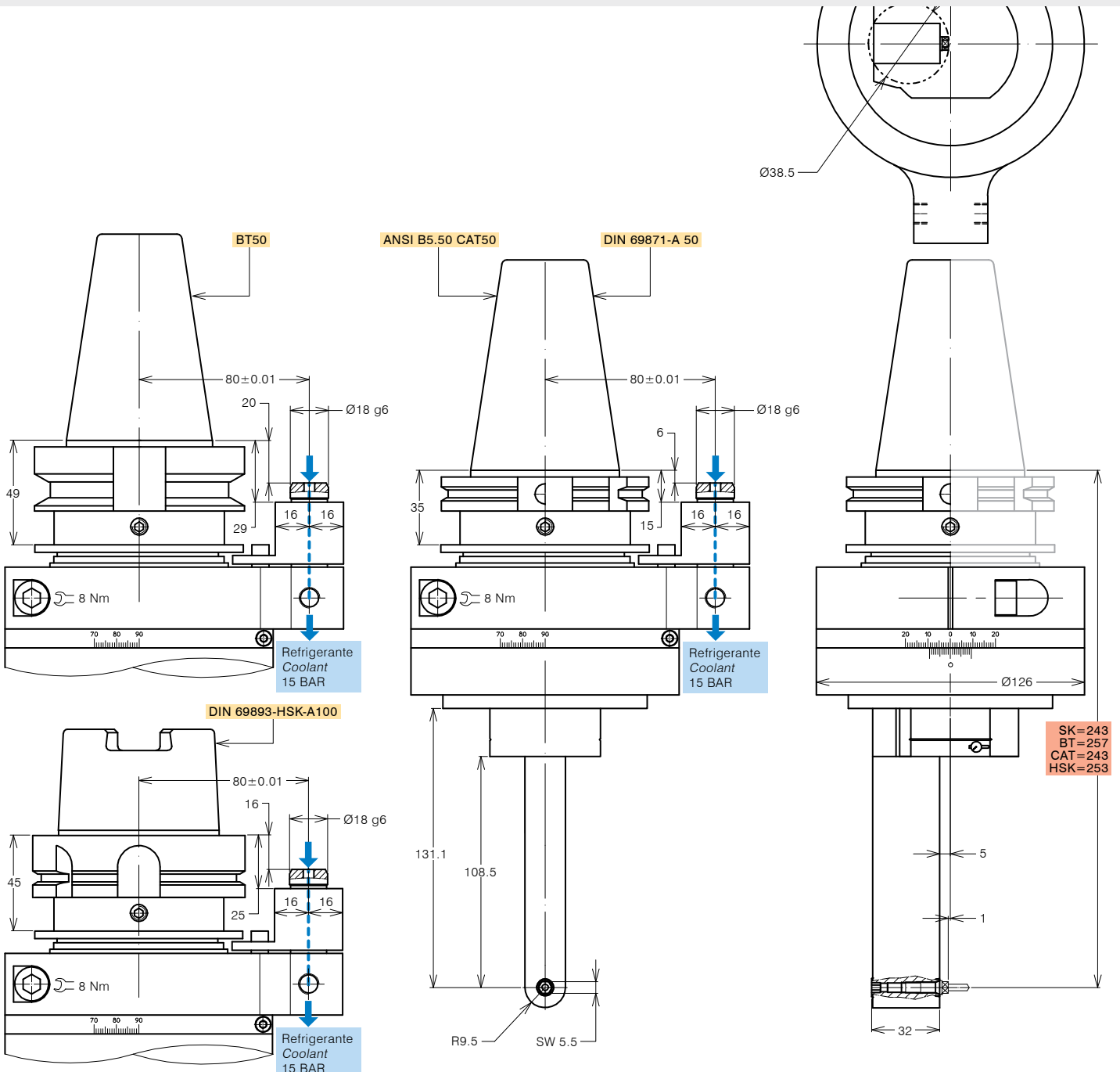



TESTE ANGOLARI SLIM SLIM ANGLE HEADS

FORATURA
DRILLING



SPECIFICHE TECNICHE TECHNICAL FEATURES

Modello <i>Type</i>	AP6-SK40	Codice <i>Code</i>	124413.100-S189
Modello <i>Type</i>	AP6-BT40	Codice <i>Code</i>	124414.100-S195
Modello <i>Type</i>	AP6-CAT40	Codice <i>Code</i>	124415.100-S189
Modello <i>Type</i>	AP6-HSK63	Codice <i>Code</i>	124416.100-S196
Mandrino porta-utensile per pinza <i>Tool-holder for collet</i>	P6 78-155		
Rotazione cono <i>Input shank rotation</i>	SX / LH		
Rotazione mandrino <i>Output spindle rotation</i>	DX / RH		
Rapporto di trasmissione <i>Transmission ratio</i>	1:1		
Velocità max <i>Max speed</i>	7000 rpm		
Coppia <i>Torque</i>	2 Nm		
Peso <i>Weight</i>	5.1 Kg		
Lubrificazione a grasso <i>Grease lubricated</i>	Klüber Isoflex NBU 15		

OPZIONI OPTIONS

Pinza P6 78-155 *P6 78-155 collet*
Perno antirotante interasse 80 mm
Pin pitch 80 mm

DOTAZIONE STANDARD STANDARD EQUIPMENT

Stop-block standard *Standard stop-block* 311201.025
Tubetto di grasso *Grease tube*
Bauletto *Storage case*

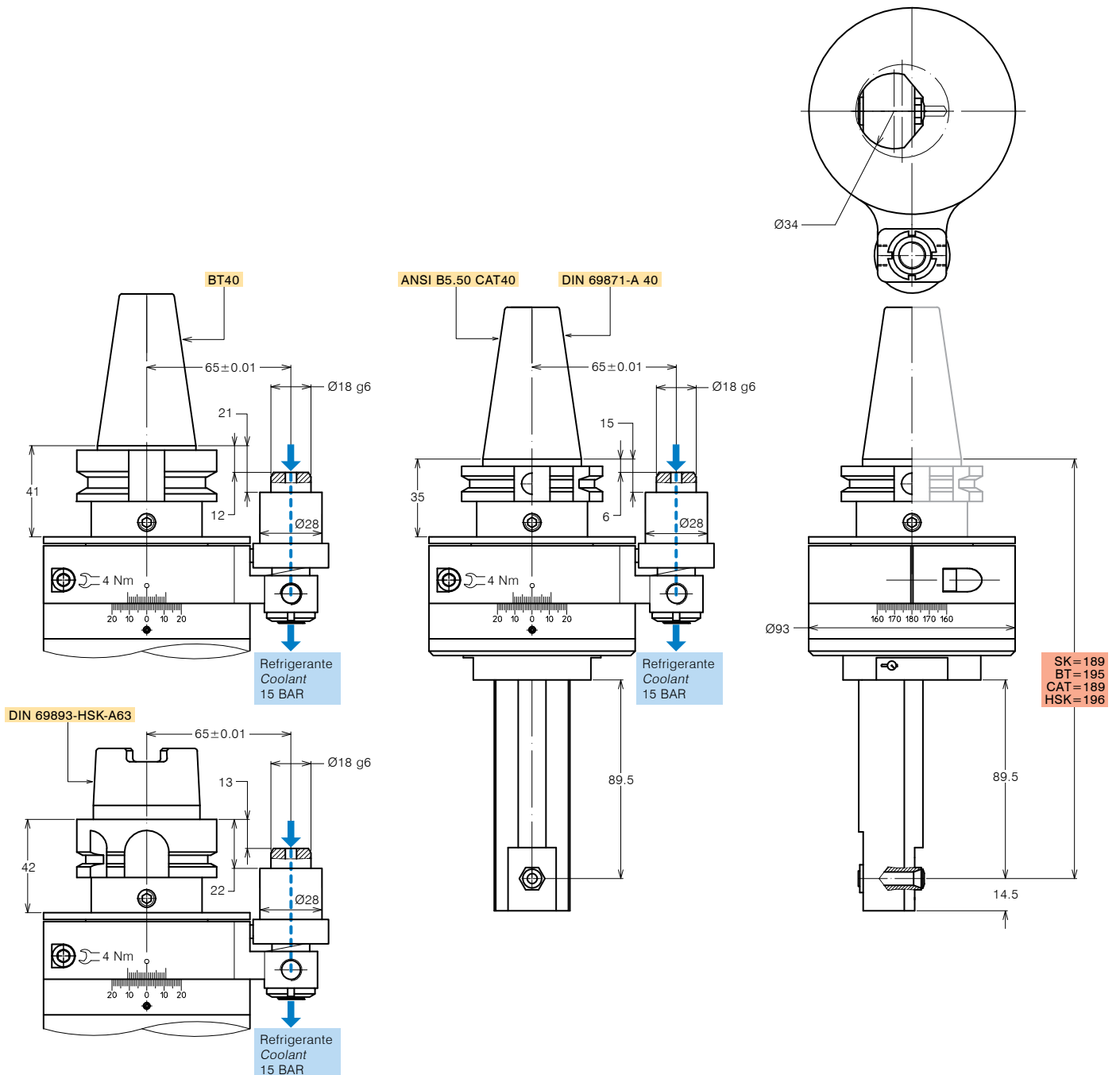



TESTE ANGOLARI SLIM SLIM ANGLE HEADS

FORATURA
DRILLING



SPECIFICHE TECNICHE TECHNICAL FEATURES

Modello *Type* AP6-SK40 Codice *Code* 124417.100-S220

Modello *Type* AP6-BT40 Codice *Code* 124418.100-S227

Modello *Type* AP6-CAT40 Codice *Code* 124419.100-S220

Modello *Type* AP6-HSK63 Codice *Code* 124420.100-S228

Mandrino porta-utensile per pinza *Tool-holder for collet* **P6 78-155**
 Rotazione cono *Input shank rotation* DX / RH
 Rotazione mandrino *Output spindle rotation* DX / RH
 Rapporto di trasmissione *Transmission ratio* 1:1
 Velocità max *Max speed* 7000 rpm
 Coppia *Torque* 4.5 Nm
 Peso *Weight* 5.1 Kg
 Lubrificazione a grasso *Grease lubricated* Klüber Isoflex NBU 15

OPZIONI OPTIONS

Pinza P6 78-155 *P6 78-155 collet*
 Perno antirotante interasse 80 mm
Pin pitch 80 mm

DOTAZIONE STANDARD STANDARD EQUIPMENT

Stop-block standard *Standard stop-block* 311201.025
 Tubetto di grasso *Grease tube*
 Bauletto *Storage case*

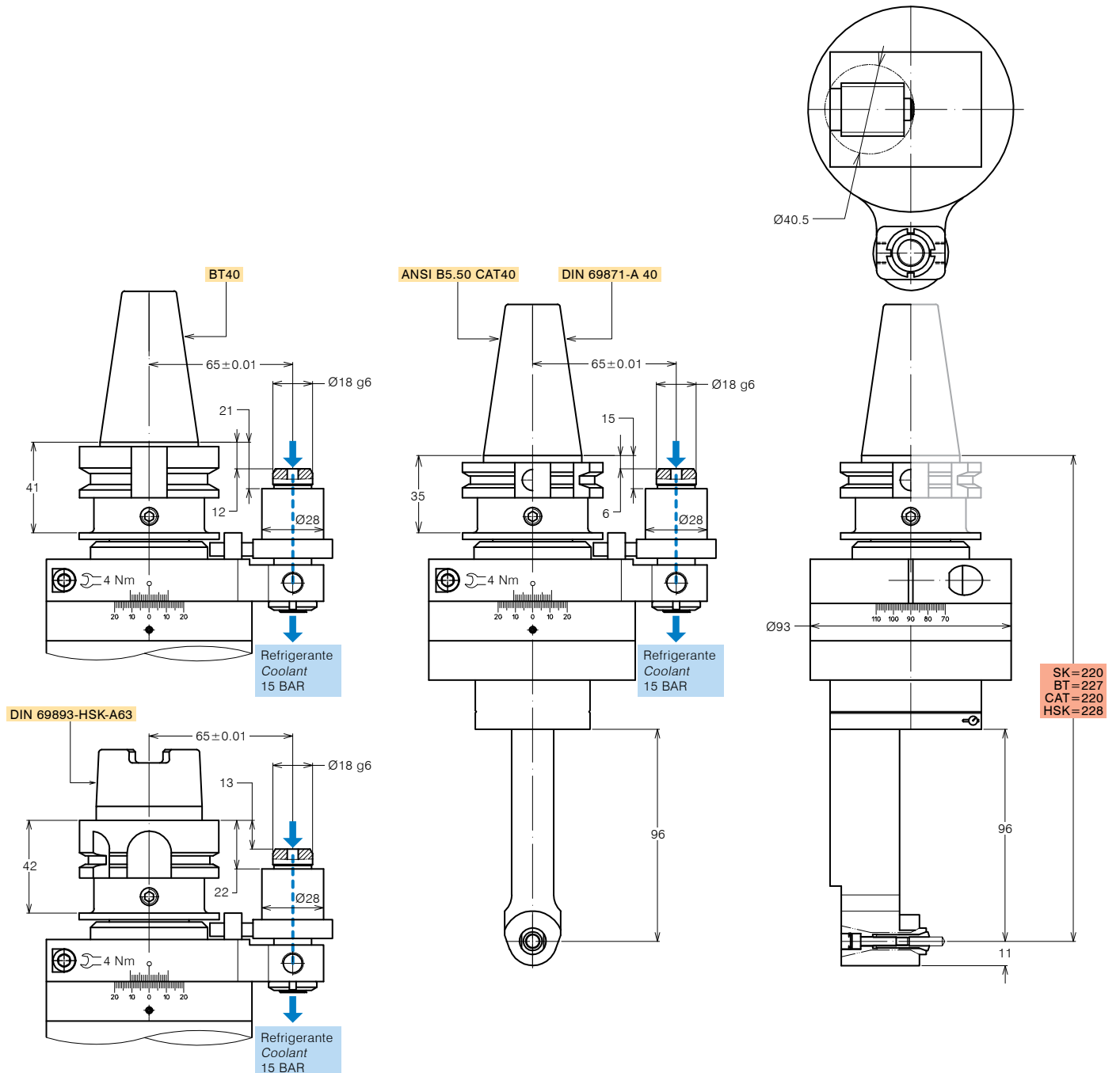



TESTE ANGOLARI SLIM SLIM ANGLE HEADS

FORATURA
DRILLING

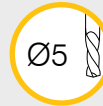

MASCHIATURA
TAPPING



SPECIFICHE TECNICHE TECHNICAL FEATURES

Modello *Type* A8-SK40-S166 Codice *Code* 1249151.100-S166

Modello *Type* A8-BT40-S172 Codice *Code* 1249152.100-S172

Modello *Type* A8-CAT40-S166 Codice *Code* 1249153.100-S166

Modello *Type* A8-HSK63-S173 Codice *Code* 1249154.100-S173

Mandrino porta-utensile per pinza *Tool-holder for collet* **ER8**
 Rotazione cono *Input shank rotation* DX / RH
 Rotazione mandrino *Output spindle rotation* DX / RH
 Rapporto di trasmissione *Transmission ratio* 1:1.5
 Velocità max *Max speed* 10000 rpm
 Coppia *Torque* 12 Nm @ 500 rpm
 Lubrificazione a grasso *Grease lubricated* Klüber Isoflex NBU 15

OPZIONI OPTIONS

Pinza ER8 DIN 6499/B *ER8 collet DIN 6499/B* 411208.100
 Perno antirotante interasse 80 mm
Pin pitch 80 mm

DOTAZIONE STANDARD STANDARD EQUIPMENT

Stop-block standard *Standard stop-block* 311201.025
 Ghiera ER *ER nut*
 Chiave *Clamping wrench*
 Tubetto di grasso *Grease tube*
 Bauletto *Storage case*

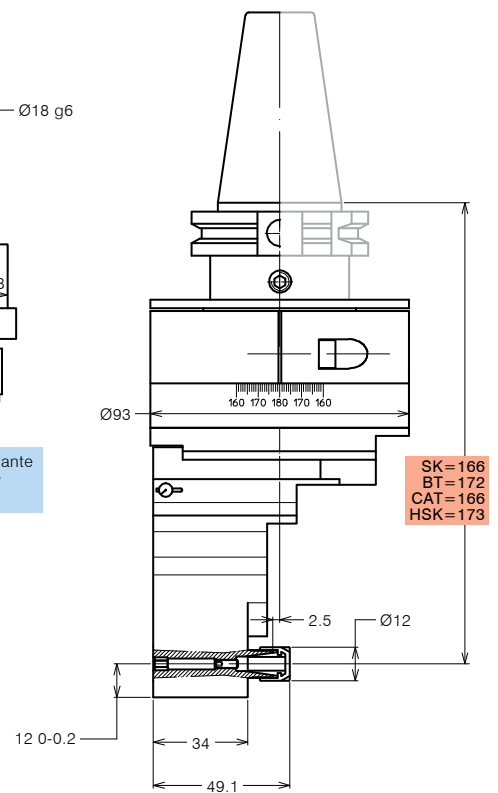
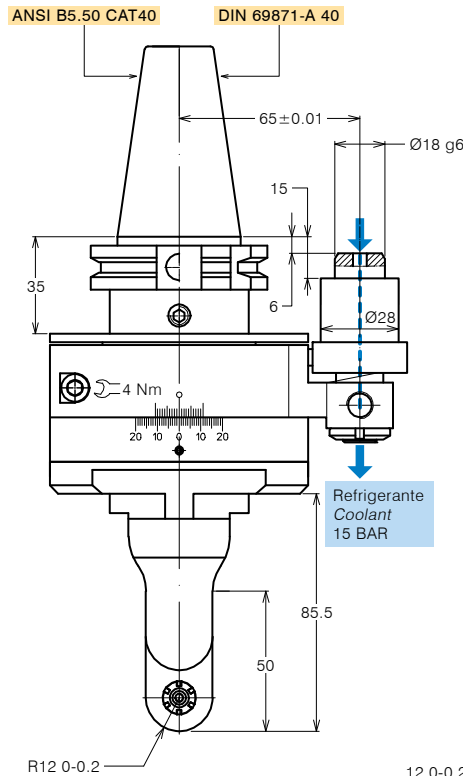
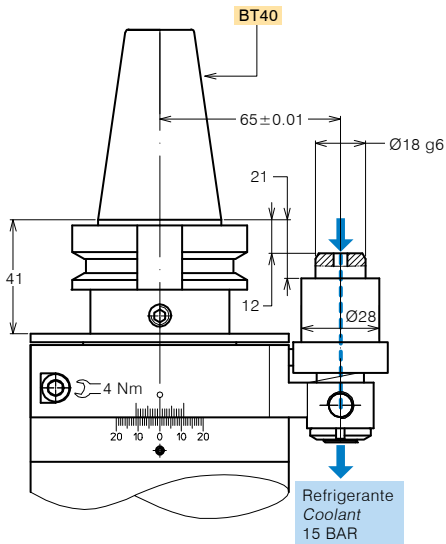
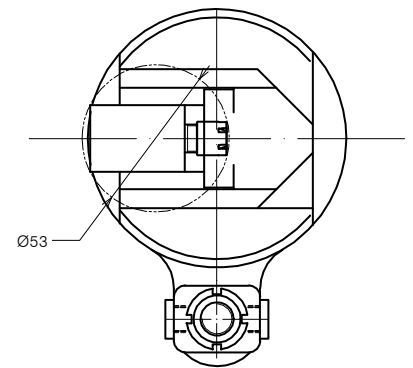

SK=166
 BT=172
 CAT=166
 HSK=173



TESTE ANGOLARI SLIM SLIM ANGLE HEADS

FORATURA
DRILLING

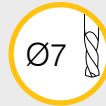

MASCHIATURA
TAPPING



SPECIFICHE TECNICHE TECHNICAL FEATURES

Modello *Type* A11-SK40-S183 Codice *Code* 124955.100-S183

Modello *Type* A11-BT40-S189 Codice *Code* 124956.100-S189

Modello *Type* A11-CAT40-S183 Codice *Code* 124997.100-S183

Modello *Type* A11-HSK63-S190 Codice *Code* 124957.100-S190

Mandrino porta-utensile per pinza <i>Tool-holder for collet</i>	ER 11
Rotazione cono <i>Input shank rotation</i>	DX / RH
Rotazione mandrino <i>Output spindle rotation</i>	DX / RH
Rapporto di trasmissione <i>Transmission ratio</i>	1:1
Velocità max <i>Max speed</i>	7000 rpm
Coppia <i>Torque</i>	12 Nm @ 500 rpm
Carico assiale max <i>Max axial load</i>	220 N
Peso <i>Weight</i>	5 Kg
Lubrificazione a grasso <i>Grease lubricated</i>	Klüber Isoflex NBU 15

OPZIONI OPTIONS

Pinza ER11 DIN 6499/B <i>ER11 collet DIN 6499/B</i>	411211.100
Pinza di maschiatura ER11 con quadro <i>Tapping collet ER11 with square</i>	411211.200
Perno antirotante interasse 80 mm <i>Pin pitch 80 mm</i>	

DOTAZIONE STANDARD STANDARD EQUIPMENT

Stop-block standard <i>Standard stop-block</i>	311201.025
Ghiera ER <i>ER nut</i>	
Chiave <i>Clamping wrench</i>	
Tubetto di grasso <i>Grease tube</i>	
Bauletto <i>Storage case</i>	

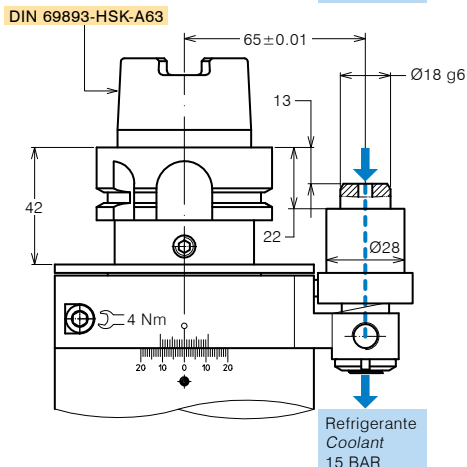
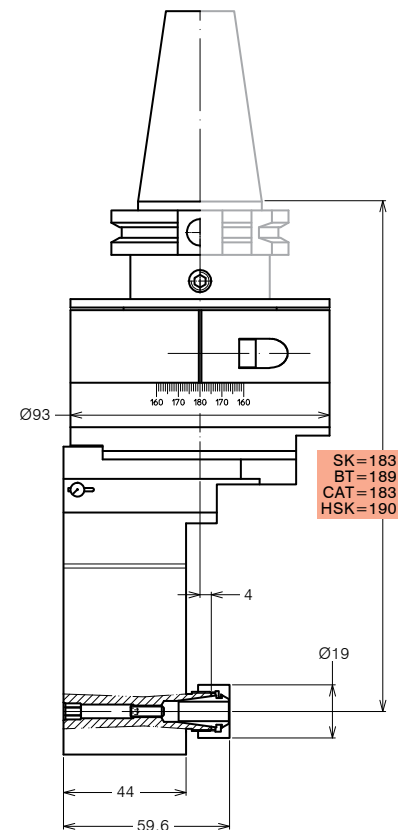
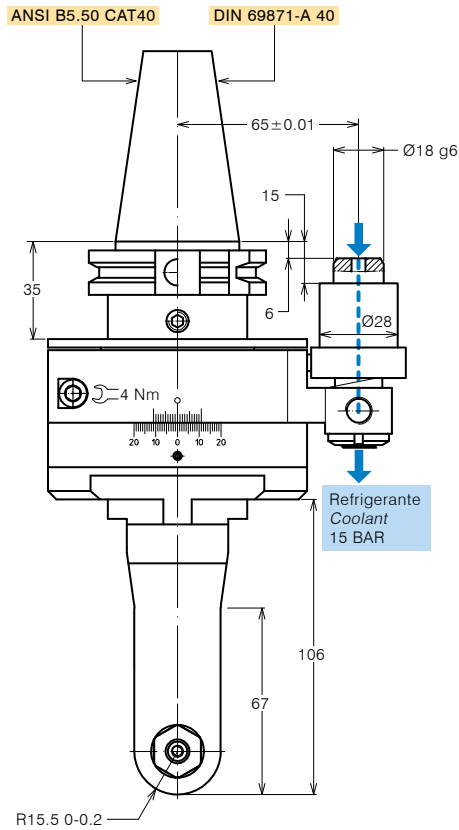
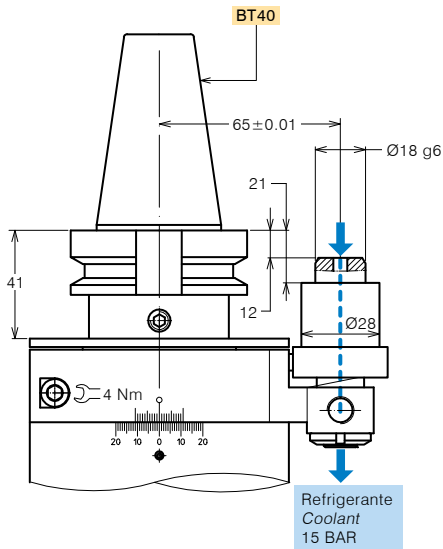
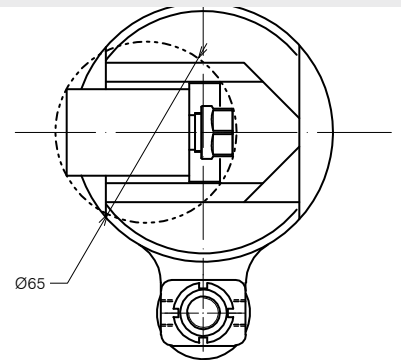



TESTE ANGOLARI SLIM SLIM ANGLE HEADS

FORATURA
DRILLING

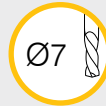

MASCHIATURA
TAPPING



SPECIFICHE TECNICHE TECHNICAL FEATURES

Modello *Type* A11-SK40-S233 Codice *Code* 124955.100-S233

Modello *Type* A11-BT40-S239 Codice *Code* 124956.100-S239

Modello *Type* A11-CAT40-S233 Codice *Code* 124997.100-S233

Modello *Type* A11-HSK63-S240 Codice *Code* 124957.100-S240

Mandrino porta-utensile per pinza <i>Tool-holder for collet</i>	ER 11
Rotazione cono <i>Input shank rotation</i>	DX / RH
Rotazione mandrino <i>Output spindle rotation</i>	DX / RH
Rapporto di trasmissione <i>Transmission ratio</i>	1:1
Velocità max <i>Max speed</i>	7000 rpm
Coppia <i>Torque</i>	12 Nm @ 500 rpm
Carico assiale max <i>Max axial load</i>	220 N
Peso <i>Weight</i>	5 Kg
Lubrificazione a grasso <i>Grease lubricated</i>	Klüber Isoflex NBU 15

OPZIONI OPTIONS

Pinza ER11 DIN 6499/B <i>ER11 collet DIN 6499/B</i>	411211.100
Pinza di maschiatura ER11 con quadro <i>Tapping collet ER11 with square</i>	411211.200
Perno antirotante interasse 80 mm <i>Pin pitch 80 mm</i>	

DOTAZIONE STANDARD STANDARD EQUIPMENT

Stop-block standard <i>Standard stop-block</i>	311201.025
Ghiera ER <i>ER nut</i>	
Chiave <i>Clamping wrench</i>	
Tubetto di grasso <i>Grease tube</i>	
Bauletto <i>Storage case</i>	

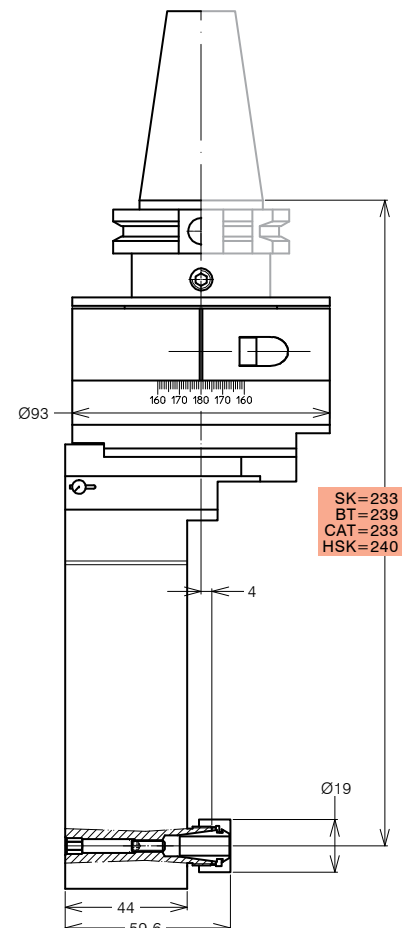
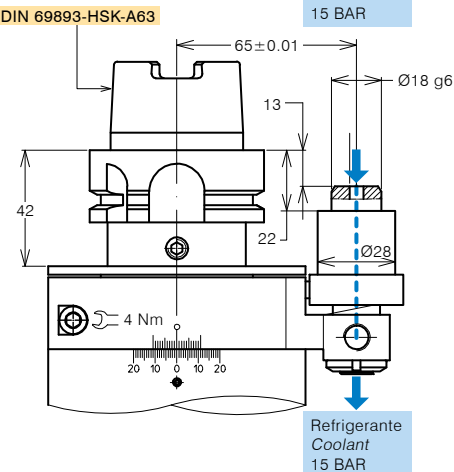
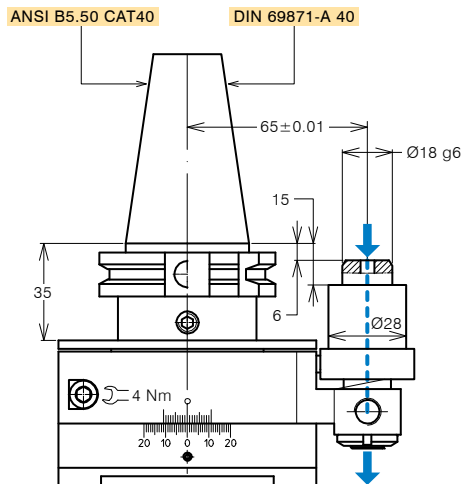
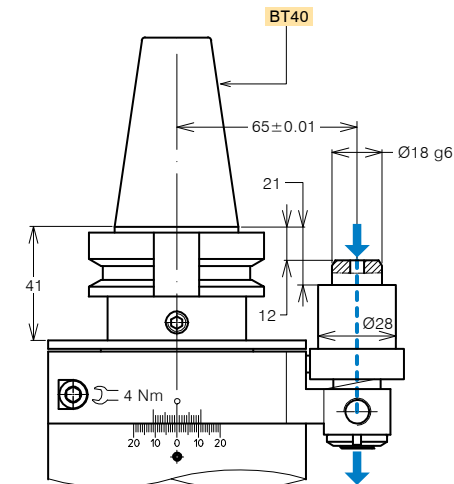
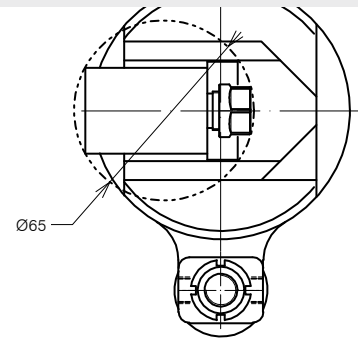

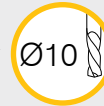
SPECIFICHE TECNICHE TECHNICAL FEATURES

 Modello *Type* A16-SK40-S258 Codice *Code* 1249203.100-S258

 Modello *Type* A16-BT40-S264 Codice *Code* 1249204.100-S264

 Modello *Type* A16-CAT40-S258 Codice *Code* 1249205.100-S258

 Modello *Type* A16-HSK63-S265 Codice *Code* 1249206.100-S265

 Mandrino porta-utensile per pinza *Tool-holder for collet* **ER 16**

 Rotazione cono *Input shank rotation* SX / LH

 Rotazione mandrino *Output spindle rotation* DX / RH

 Rapporto di trasmissione *Transmission ratio* 1:1

 Velocità max *Max speed* 6000 rpm

 Coppia *Torque* 14 Nm @ 500 rpm

 Carico assiale max *Max axial load* 150 N

 Peso *Weight* 6.5 Kg

 Lubrificata a grasso *Grease lubricated* Klüber Isoflex NBU 15

OPZIONI OPTIONS

 Pinza ER16 DIN 6499/B *ER16 collet DIN 6499/B* 411216.100

 Pinza di maschiatura ET-1-16 con compensazione *401216.200*
Tapping collet ET-1-16 with compensation

 Pinza di maschiatura ER16 con quadro *411216.200*
Tapping collet ER16 with square

Perno antirotante interasse 110 mm

Pin pitch 110 mm
DOTAZIONE STANDARD STANDARD EQUIPMENT

 Stop-block standard *Standard stop-block* 311201.025

 Ghiera ER *ER nut*

 Chiave *Clamping wrench*

 Tubetto di grasso *Grease tube*

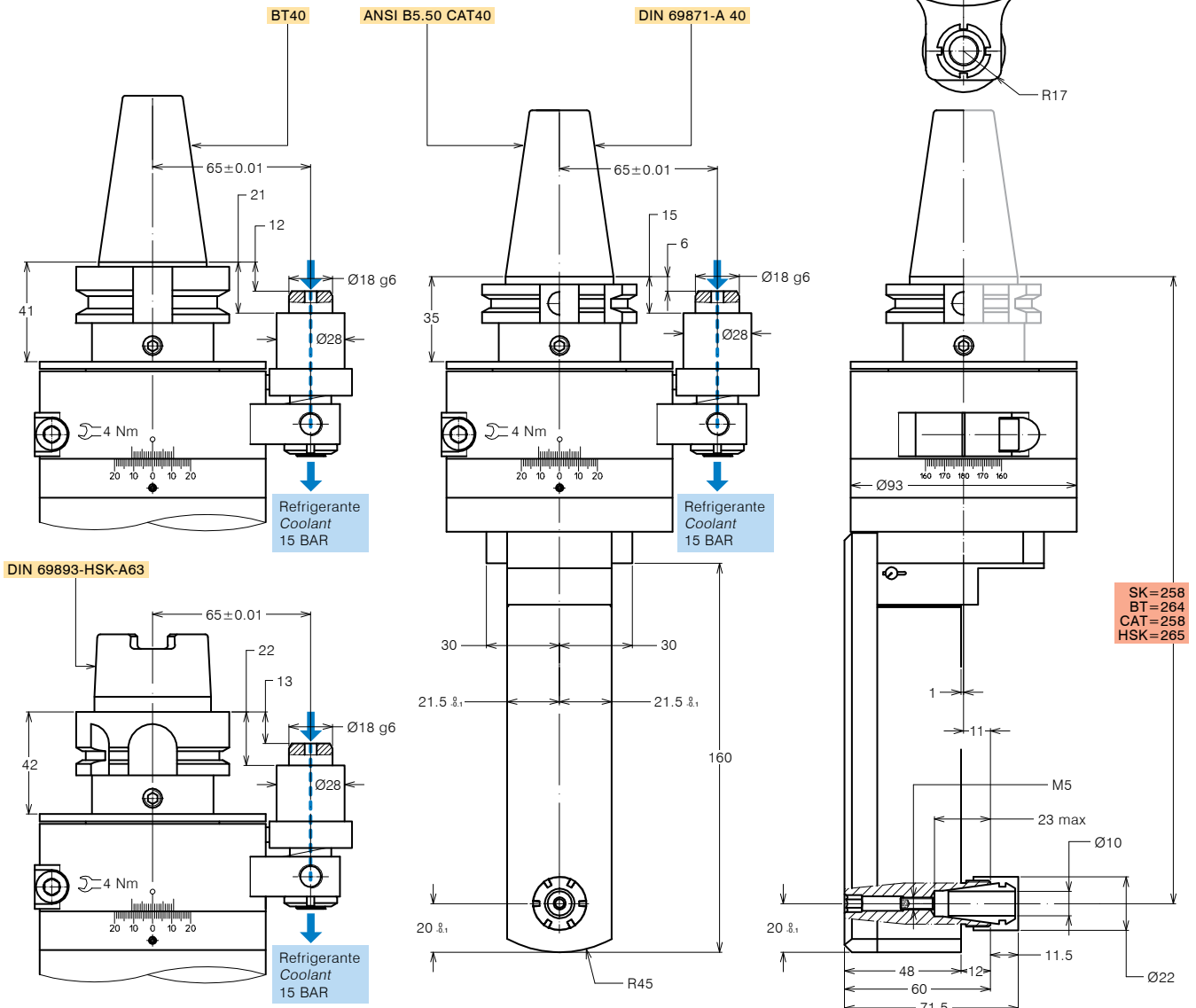
 Bauletto *Storage case*



TESTE ANGOLARI SLIM SLIM ANGLE HEADS

FORATURA
DRILLING

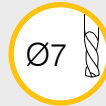

MASCHIATURA
TAPPING



SPECIFICHE TECNICHE TECHNICAL FEATURES

Modello <i>Type</i>	A11-SK50-S256	Codice <i>Code</i>	124972.100-S256
Modello <i>Type</i>	A11-BT50-S270	Codice <i>Code</i>	124973.100-S270
Modello <i>Type</i>	A11-CAT50-S256	Codice <i>Code</i>	124974.100-S256
Modello <i>Type</i>	A11-HSK100-S266	Codice <i>Code</i>	124975.100-S266
Mandrino porta-utensile per pinza <i>Tool-holder for collet</i>	ER 11		
Rotazione cono <i>Input shank rotation</i>	DX / RH		
Rotazione mandrino <i>Output spindle rotation</i>	DX / RH		
Rapporto di trasmissione <i>Transmission ratio</i>	1:1		
Velocità max <i>Max speed</i>	7000 rpm		
Coppia <i>Torque</i>	12 Nm @ 500 rpm		
Peso <i>Weight</i>	10,5 Kg		
Lubrificazione a grasso <i>Grease lubricated</i>	Klüber Isoflex NBU 15		

OPZIONI OPTIONS

Pinza ER11 DIN 6499/B <i>ER11 collet DIN 6499/B</i>	411211.100
Pinza di maschiatura ER11 con quadro <i>Tapping collet ER11 with square</i>	411211.200
Perno antirotante interasse 110 mm <i>Pin pitch 110 mm</i>	

DOTAZIONE STANDARD STANDARD EQUIPMENT

Stop-block standard <i>Standard stop-block</i>	311201.025
Ghiera ER <i>ER nut</i>	
Chiave <i>Clamping wrench</i>	
Tubetto di grasso <i>Grease tube</i>	
Bauletto <i>Storage case</i>	

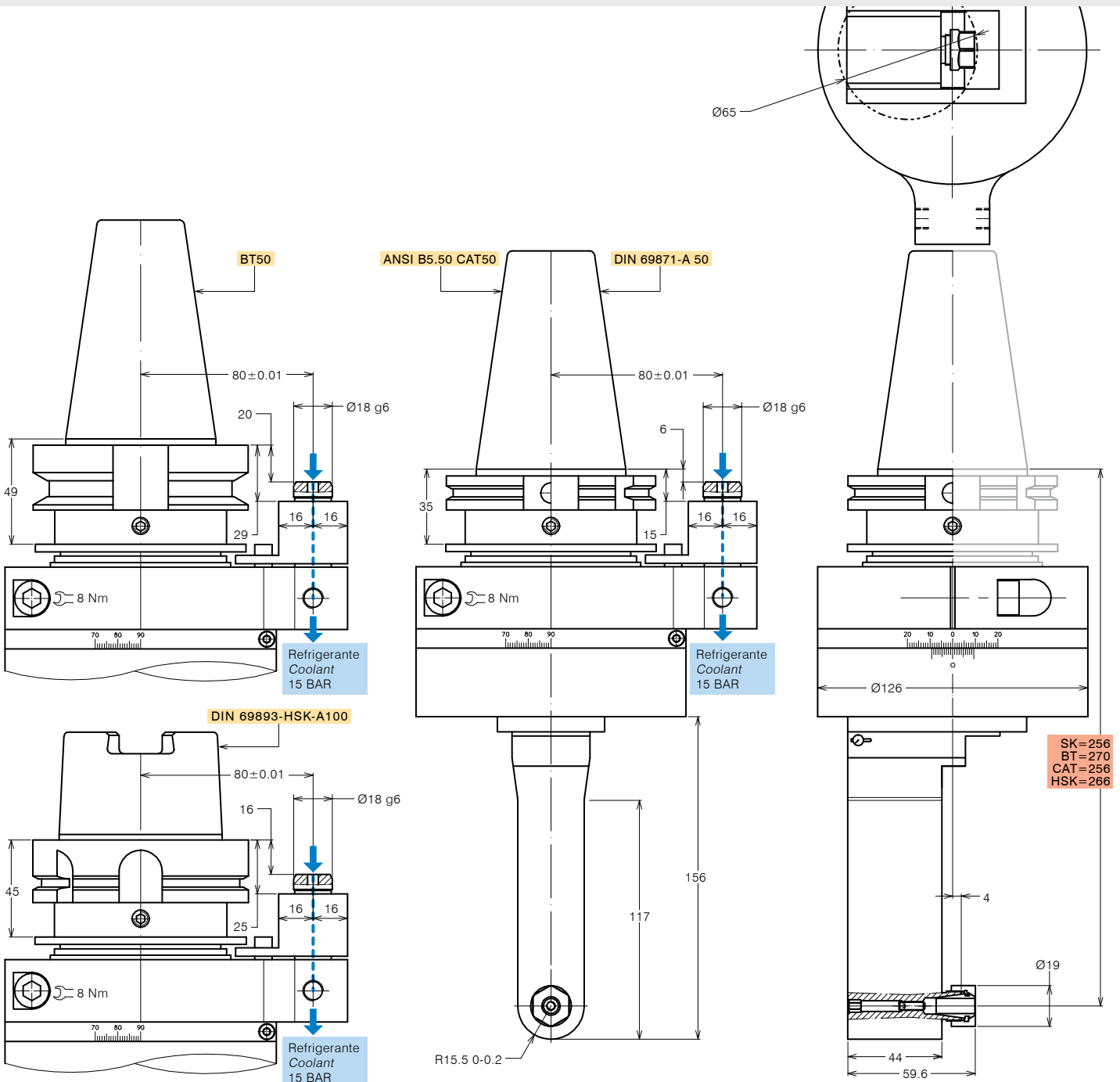

SPECIFICHE TECNICHE TECHNICAL FEATURES

 Modello *Type* A11-SK50-D250 Codice *Code* 1249102.100-D250

 Modello *Type* A11-BT50-D264 Codice *Code* 1249101.100-D264

 Modello *Type* A11-CAT50-D250 Codice *Code* 1249103.100-D250

 Modello *Type* A11-HSK100-D260 Codice *Code* 1249104.100-D260

 Mandrino porta-utensile per pinza *Tool-holder for collet* **ER 11**

 Rotazione cono *Input shank rotation* SX / DX - LH / RH

 Rotazione mandrino *Output spindle rotation* DX / RH

 Rapporto di trasmissione *Transmission ratio* 1:1.3

 Velocità max *Max speed* 8000 rpm

 Coppia *Torque* 12 Nm @ 500 rpm

 Peso *Weight* 11 Kg

 Lubrificata a grasso *Grease lubricated* Klüber Isoflex NBU 15

OPZIONI OPTIONS

 Pinza ER11 DIN 6499/B *ER11 collet DIN 6499/B* 411211.100

 Pinza di maschiatura ER11 con quadro *Tapping collet ER11 with square* 411211.200

 Mandrino Weldon *Weldon spindle type*

Perno antirotante interasse 110 mm

Stop-bar pin pitch 110 mm

DOTAZIONE STANDARD STANDARD EQUIPMENT

 Stop-block standard *Standard stop-block* 311201.025

 Ghiera ER *ER nut*

 Chiave *Clamping wrench*

 Tubetto di grasso *Grease tube*

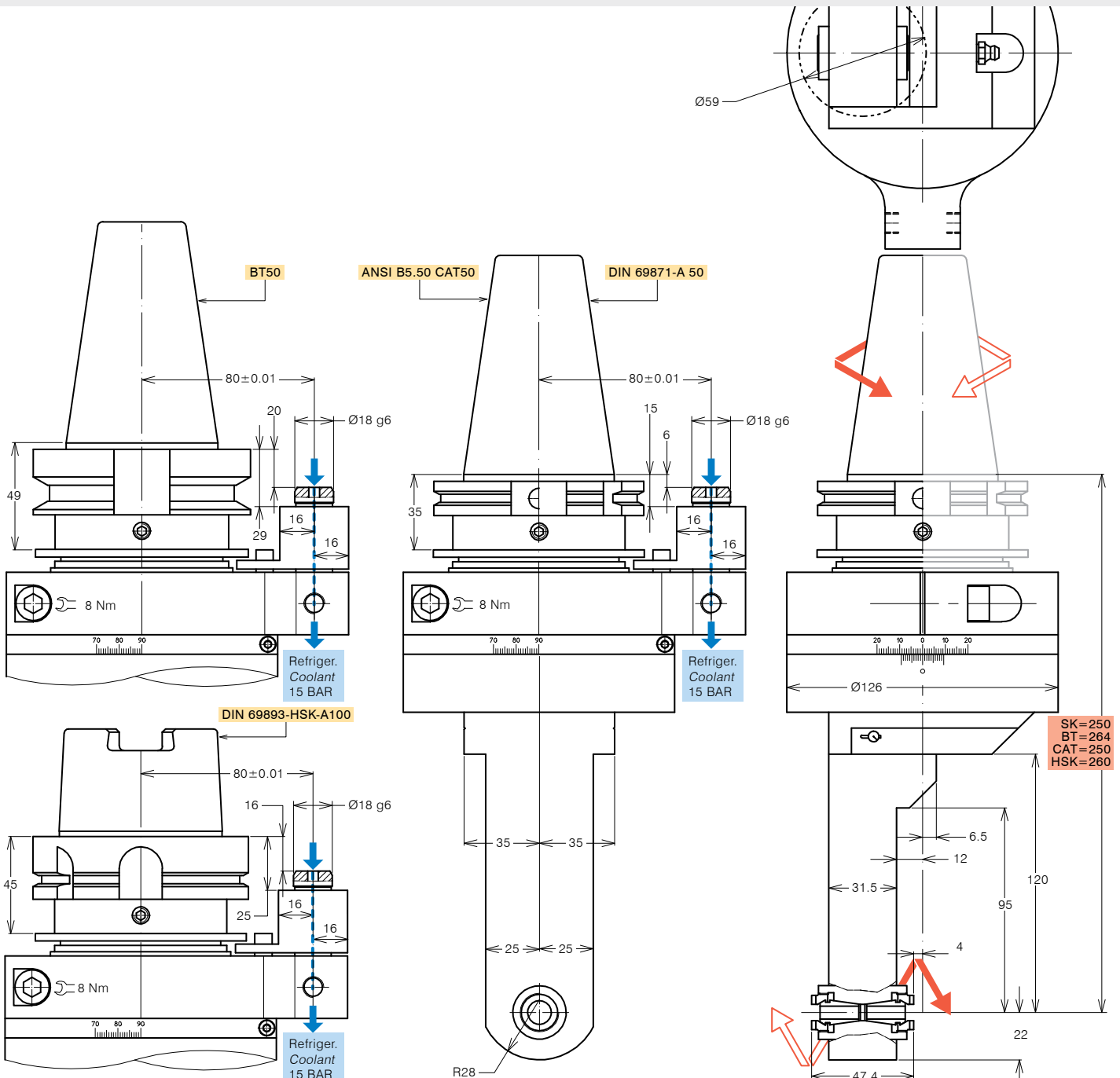
 Bauletto *Storage case*

SPECIFICHE TECNICHE TECHNICAL FEATURES

 Modello *Type* A16-SK50-S265 Codice *Code* 1249179.100-S265

 Modello *Type* A16-BT50-S279 Codice *Code* 1249180.100-S279

 Modello *Type* A16-CAT50-S265 Codice *Code* 1249181.100-S265

 Modello *Type* A16-HSK100-S275 Codice *Code* 1249182.100-S275

 Mandrino porta-utensile per pinza *Tool-holder for collet* **ER 16**

 Rotazione cono *Input shank rotation* SX / LH

 Rotazione mandrino *Output spindle rotation* DX / RH

 Rapporto di trasmissione *Transmission ratio* 1:1

 Velocità max *Max speed* 6000 rpm

 Coppia *Torque* 14 Nm @ 500 rpm

 Carico assiale max *Max axial load* 500 N

 Peso *Weight* 15 Kg

 Lubrificata a grasso *Grease lubricated* Klüber Isoflex NBU 15

OPZIONI OPTIONS

 Pinza ER16 DIN 6499/B *ER16 collet DIN 6499/B* 411216.100

 Pinza di maschiatura ER16 con quadro *Tapping collet ER16 with square* 411216.200

Tapping collet ER16 with square

Perno antirotante interasse 110 mm

Pin pitch 110 mm
DOTAZIONE STANDARD STANDARD EQUIPMENT

 Stop-block standard *Standard stop-block* 311201.025

 Ghiera ER *ER nut*

 Chiave *Clamping wrench*

 Tubetto di grasso *Grease tube*

 Bauletto *Storage case*
